

OPTICON

Laser Multi-barcode Scanner

OPV 1001



The OPV 1001 is a 1000 scans multi-barcode laser scanner reading for omni-directional reading.

Specifications Manual

All information subject to change without notice.

Document History

Model Number:	OPV 1001	Specification Number:	SS06175
Edition:	6	Original Spec Number:	SS06172
Date:	2008-04-07		

Copyright 2008 Opticon. All rights reserved.

This manual may not, in whole or in part, be copied, photocopied, reproduced, translated or converted to any electronic or machine readable form without prior written consent of Opticon.

Limited Warranty and Disclaimers

PLEASE READ THIS MANUAL CAREFULLY BEFORE INSTALLING OR USING THE PRODUCT.

Serial Number

A serial number appears on all Opticon products. This official registration number is directly related to the device purchased. Do not remove the serial number from your Opticon device. Removing the serial number voids the warranty.

Warranty

Unless otherwise agreed in a written contract, all Opticon products are warranted against defects in materials and workmanship for two years after purchase. Opticon will repair or, at its option, replace products that are defective in materials or workmanship with proper use during the warranty period. Opticon is not liable for damages caused by modifications made by a customer. In such cases, standard repair charges will apply. If a product is returned under warranty and no defect is found, standard repair charges will apply. Opticon assumes no liability for any direct, indirect, consequential or incidental damages arising out of use or inability to use both the hardware and software, even if Opticon has been informed about the possibility of such damages.

Packaging

The packing materials are recyclable. We recommend that you save all packing material to use should you need to transport your scanner or send it for service. Damage caused by improper packaging during shipment is not covered by the warranty.

Trademarks

Trademarks used are the property of their respective owners.

Opticon Inc. and Opticon Sensors Europe B.V. are wholly owned subsidiaries of OPTOELECTRONICS Co., Ltd., 12-17, Tsukagoshi 4-chome, Warabi-shi, Saitama, Japan 335-0002. TEL +81-(0) 48-446-1183; FAX +81-(0) 48-446-1184

SUPPORT

USA

Phone: 800-636-0090

Email: support@opticonusa.com

Web: www.opticonusa.com

Europe

Email: support@opticon.com

Web: www.opticon.com

Contents

1. Abstract	7
2. Overview	7
3. Physical Features	8
3.1. Dimensions	8
3.2. Weight	8
4. Environmental Specifications	8
4.1. Operating Temperature and Humidity	8
4.2. Storage Temperature and Humidity	8
4.3. Ambient Light Immunity	8
5. Electrical Specifications	9
5.1. Power Supply	9
5.2. AC Adapter	9
5.3. Operating Indicators	9
5.3.1. Red	9
5.3.2. Green	9
6. Optical Specifications	10
6.1. Laser Scan Specifications	10
7. Technical Specifications	10
7.1. Print Contrast Signal (PCS)	10
7.2. Minimum Resolution	10
7.3. Scan Area and Resolution	11
7.3.1. Scan Area	11
7.3.2. Depth of Field	11
7.4. Pitch, Skew, and Tilt	13
7.4.1. Pitch Angle	13
7.4.2. Skew Angle and Dead Zone	13
7.4.3. Tilt	14
7.5. Curvature	15
8. Interface Specifications	16
8.1. RS-232C Interface	16
8.1.1. Settings and Communication	16
8.1.2. Signal Level	16

8.1.3.	Pin Assignment	16
8.1.4.	Interface Circuit	17
8.1.5.	Character Format	17
8.1.6.	Communication Format	17
8.1.7.	Handshaking	18
8.2.	USB Interface Specifications	23
8.2.1.	Connector	23
8.2.2.	Interface Circuit	23
8.3.	DOS/V Wedge Interface Specification	24
8.3.1.	Connectors	24
9.	Cable and Connector	26
9.1.	Cables	26
9.1.1.	RS-232C	26
9.1.2.	USB Cable	26
9.1.3.	DOS V/Wedge Cable	27
9.2.	Connectors	27
10.	Default Settings	27
10.1.	Set Default Interface	27
10.2.	Default Settings 1: Readable Codes	29
10.3.	Default Settings 2: Read Options, Trigger, Buzzer	30
11.	Serial Number	31
12.	Packaging Specifications	32
12.1.	Accessory Specifications	32
12.2.	Collective Packaging Specification	33
13.	Durability	34
13.1.	Static Electricity	34
13.2.	Shock	34
13.2.1.	Drop Test (without packaging)	34
13.2.2.	Drop Test (with individual packaging)	34
13.3.	Vibration Strength	34
13.4.	Cable Strength	35
13.5.	Cable Bending Test	35
14.	Reliability	35
15.	Trigger and Read Options	36

15.1. Trigger Modes	36
15.2. Read modes	36
16. Trigger and Read Settings	37
16.1. Auto Trigger Enable/Disable Settings	37
17. Power Saving	38
17.1. Motor speed	38
17.2. Auto Shut-off Time	38
17.3. Power Saving 2 (Motor Rotation—1/2)	39
17.4. Power Saving 3 (Motor Rotation—Stop)	39
18. Regulatory Compliance	42
18.1. Laser Safety	42
18.2. Product Safety	42
18.3. EMC	42
18.4. RoHS	42
19. Safety	43
19.1. Shock	43
19.2. Temperature Conditions	43
19.3. Foreign Materials	43
19.4. Other	43
20. Mechanical Drawing	44
20.1. OPV 1001 (without stand)	44
20.2. OPV 1001 (with stand)	44

Table of Figures

Figure 1: Scan area	11
Figure 2: Depth of field	12
Figure 3: Pitch	13
Figure 4: Skew and dead zone	13
Figure 5: Tilt	14
Figure 6: Curvature	15
Figure 7: Interface circuit (RS-232C)	17
Figure 8: Character format (same for both sending and receiving)	17
Figure 9: Communication format	17
Figure 10: No handshaking	18
Figure 11: Busy/Ready communication	18
Figure 12: Handshaking Busy/Ready	19
Figure 13: Signal timing	19

Figure 14: Handshaking: Modem mode 20

Figure 15: Handshaking: ACK/NAK 21

Figure 16: Handshaking: ACK/NAK—No response 22

Figure 17: USB "A" connector 23

Figure 18: Interface circuit (USB) 23

Figure 19: Wedge connector (host side)..... 24

Figure 20: Wedge connector (keyboard side)..... 24

Figure 21: Wedge connector (DOS/V side) 25

Figure 22: RS-232C cable 26

Figure 23: USB cable 26

Figure 24: Wedge cable..... 27

Figure 25: Serial number diagram 31

Figure 26: Individual packaging diagram 32

Figure 27: Collective packaging..... 33

Figure 28: Drop test..... 34

Figure 29: Cable tail bending test..... 35

Figure 30: Auto-trigger detection area 37

Figure 31: Menu code combinations (part 1)..... 40

Figure 32: Menu code combinations (part 2)..... 41

Figure 33: Mechanical drawing (without stand) 44

Figure 34: Mechanical drawing(with stand) 44

1. Abstract

This manual provides specifications for the OPV 1001 laser multi-barcode scanner.

2. Overview

The OPV 1001 outputs laser beams in multiple directions (4 lines each in 5 directions) to scan barcodes. For non-contact scanning, a barcode needs to face the scan window of the OPV 1001.

For periods of inactivity, the power saving mode (laser disabled, motor off) can be set using commands or menu barcodes. Power saving mode will be automatically disabled when the brightness in front of the scanner is changed; for example, when an object is placed in front of the scanner.

You can use a dedicated stand (an accessory, sold separately) to adjust the height and angle of the scanner.

The feature settings of the OPV 1001 are configured either by scanning menu barcodes or by sending commands.

The OPV 1001 outputs scanned data through any of the following interfaces: RS-232C, Keyboard Wedge, or USB.

Supported symbologies:

Linear (1D)

JAN/UPC/EAN, incl. add-on

Codabar/NW-7

Code 11

Code 39

Code 93

Code 128

GS1-128 (EAN-128)

IATA

Industrial 2of5

Interleaved 2of5

ISBN-ISMN-ISSN

Matrix 2of5

MSI/Plessey

S-Code

Telepen

Tri-Optic

UK/Plessey

Postal Code

Chinese Post

3. Physical Features

3.1. Dimensions

(Without stand) W 71.0 x D 79.4 x H 100.0 mm

3.2. Weight

OPV 1001: 200 g (max.) excluding the cable

Stand: 340 g (max.)

4. Environmental Specifications

4.1. Operating Temperature and Humidity

Temperature: 0 to +40° C

Humidity: 20 to 90% RH

4.2. Storage Temperature and Humidity

Temperature: -30 to +60° C

Humidity: 20 to 90% RH

4.3. Ambient Light Immunity

Decoding performance is guaranteed when the range of illumination on a barcode surface is between zero and the following values:

Incandescent light	3,000 lx
Fluorescent light	3,000 lx
Sunlight	20,000 lx

Conditions

Barcode Sample: OPTOELECTRONICS Test Sample

PCS:	0.9
Resolution:	0.25 mm
Symbology:	9-digit Code 39
Quiet zone:	10 mm
N/W ratio:	1:2.5
Distance:	150 mm
Angle (see note below):	$\alpha = 0^\circ \beta = 15^\circ \gamma = 0^\circ$
Curvature:	$R = \infty$
Power supply voltage:	5.0 V

Direct light or specular reflection from a light source should be prevented from entering the acceptance area.

Note: α , β and γ respectively represent pitch, skew and tilt. Please see section 0 for how these values are defined.

5. Electrical Specifications

5.1. Power Supply

Input voltage	DC 5 V \pm 5 % (6 V also supported)
Power ripple	up to 100 mVp-p (10 Hz to 100 kHz DC 5V)
Current consumption	up to 500 mA

Conditions:

- Connect 1 Ω resistance to a power supply line in series and measure the current by the voltage between both ends of resistance.
- Power supply voltage is measured at a connector terminal area.
- The current value depends on the interface type and the host computer to which the device is connected.

5.2. AC Adapter

Input:	
Input voltage	AC 90 V to 264 V
Power supply frequency	47 Hz to 63 Hz
Maximum current	up to 400 mA (at 100 V AC/50 Hz)
Rush current	up to 70 A
Output:	
Output voltage	DC 5 V \pm 5% (6 V also supported)
Output ripple	up to 100 mVp-p
Maximum current	2000 mA
Startup time	up to 20 ms (AC100V/50 Hz, 5% to 95% of output voltage)

5.3. Operating Indicators

5.3.1. Red

- Lights up when any unsupported menu is read in the menu mode (200 ms with error buzzer).
- Blinks when motor failure occurs (indefinitely).

5.3.2. Green

- Good read: when reading is done successfully.

6. Optical Specifications

6.1. Laser Scan Specifications

Parameter	Specification	Unit
Light-emitting element	Red laser diode	–
Emission wavelength	650 ±10 (25° C)	nm
Light output	1.0 or less (measured at the front of the scanner's plastic mask)	mW
Scanning method	Rastering omni-directional scanning	–
Scanning speed	1000 ±50	scans/s

7. Technical Specifications

The conditions for technical specifications are as follows, unless otherwise specified in each section.

Conditions

Ambient temperature and humidity:	Room temperature (5 to 35° C) Room humidity (45% to 85% RH)
Ambient light:	500 to 1000 lx
Background:	Barcode = black Space = white Margin = white Background of label = black
Power supply voltage:	5.0 V
Decoding test:	Approve the performance when decoding is successful in all ten tests. (Decoding is deemed successful when completed in 0.5 seconds or less.)

7.1. Print Contrast Signal (PCS)

0.45 or higher (over 70% of reflectivity of space and quiet zone).

$$PCS = \frac{\text{Reflectance of white bar} - \text{Reflectance of black bar}}{\text{Reflectance of white bar}}$$

Scanning performance may decline if dirt or scratches mar the optical window. Keep the optical window clean.

7.2. Minimum Resolution

0.127 mm

7.3. Scan Area and Resolution

7.3.1. Scan Area

The scannable area depends on the barcode type (PCS, resolution, length, etc.) and the direction of the barcode surface. However, the barcode should be set within the following area.

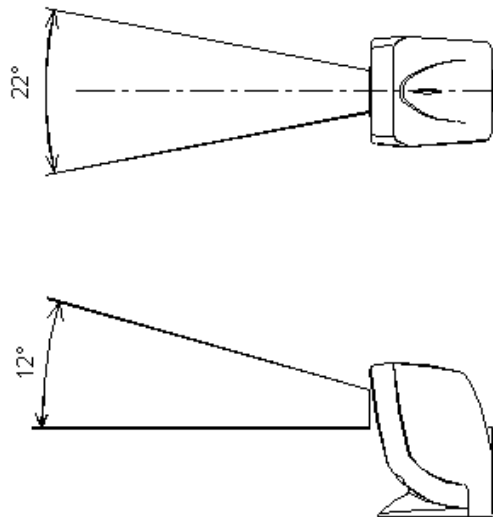

Figure 1: Scan area

Note: Binary codes are more likely to cause scanning errors than multi-level codes. To minimize problems, fix the length of binary codes.

7.3.2. Depth of Field

The depth of field is measured from the edge of the scanner. The scanning range is within the circular arc centered on the scan origin.

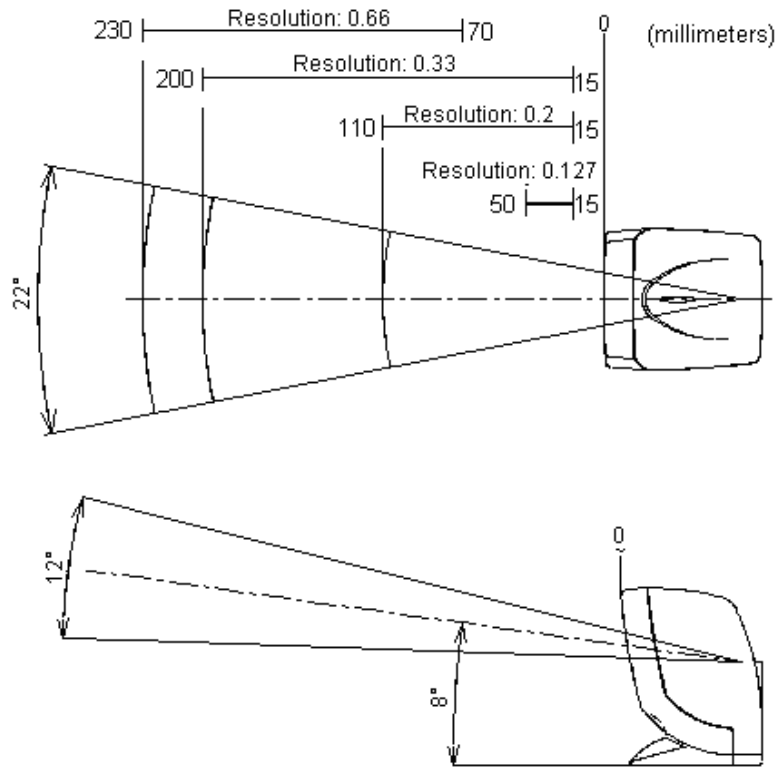

Figure 2: Depth of field

PCS	Resolution (mm)	Decode Depth (mm)
0.9	0.66	70 - 230
0.9	0.33	15 - 200
0.9 or higher	0.2	15 - 110
0.9	0.127	15 - 50

Resolution (mm)	Symbology	Digit	Barcode Sample
0.66	JAN-8	8	OPTOELECTRONICS Test Sample
0.33	JAN-13	13	OPTOELECTRONICS Test Sample
0.2	Code 39	7	Laser printer labels
0.127	Code 39	4	OPTOELECTRONICS Test Sample

Conditions

Barcode Sample: OPTOELECTRONICS Test Sample

- N/W Ratio: 1:2.5
- Angle: $\alpha = 0^\circ, \beta = 15^\circ, \gamma = 0^\circ$
- Curvature: $R = \infty$

7.4. Pitch, Skew, and Tilt

7.4.1. Pitch Angle

$$\alpha = \pm 35^\circ$$

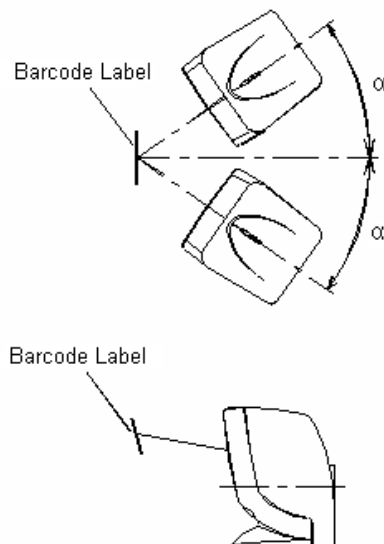

Figure 3: Pitch

7.4.2. Skew Angle and Dead Zone

Skew angle: $\beta = \pm 50^\circ$ (Excluding dead zone)

Dead zone: $\beta = \pm 8^\circ$ (There are some areas in which decoding fails due to specular reflection)

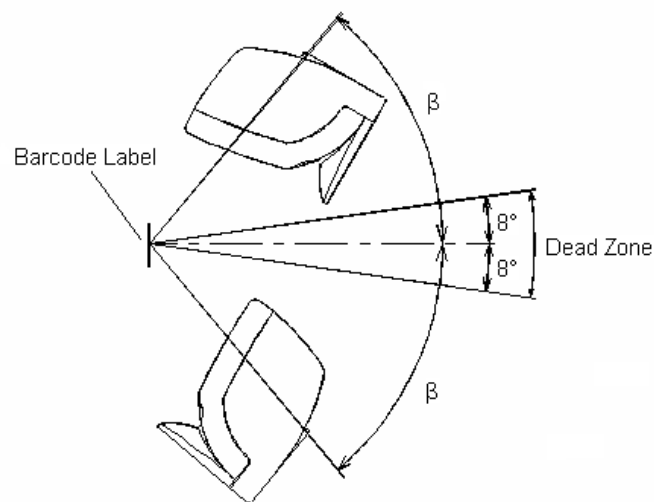

Figure 4: Skew and dead zone

7.4.3. Tilt

$\gamma = 360^\circ$

There are some angles at which decoding fails, depending on the height of a barcode.

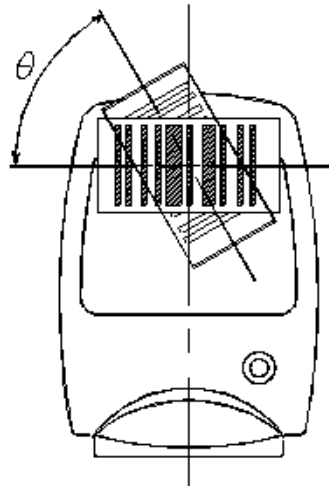

Figure 5: Tilt

Conditions

Barcode Sample: OPTOELECTRONICS Test Sample

Distance:	70 mm from the front edge of the scanner
Label:	Pitch, Skew Angle PCS = 0.9, Resolution = 0.33 mm, Symbology = JAN-13 Position The center of the barcode and the scan line are almost the same (refer to the following figure).
Angle:	Curvature: $R = \infty$, skew angle $\beta = +10^\circ$ (for measuring pitch angle and tilt angle)

Note: The specifications are decided on one horizontal scan line, except Tilt.

7.5. Curvature

With 8-digit JAN/UPC/EAN barcodes, decoding performance is guaranteed when $R \geq 20$ mm.

With 13-digit JAN/UPC/EAN barcodes, decoding performance is guaranteed when $R \geq 25$ mm.

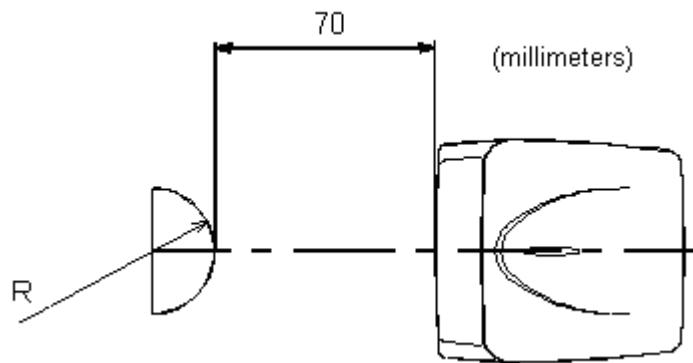

Figure 6: Curvature

Conditions

Barcode Sample: OPTOELECTRONICS Test Sample

PCS = 0.9, Resolution = 0.33 mm

8. Interface Specifications

The interface type is determined automatically, depending on the cable type.

8.1. RS-232C Interface

8.1.1. Settings and Communication

Item	[U2] setting
Baud rate	9600 bps
Start/stop bits	1 bit
Data bits	8 bits
Parity bits	No parity
Handshaking	No handshake
Flow control time out	Indefinitely

You can change the communication condition using the menu barcode.

8.1.2. Signal Level

Signal Name	I/O	RS-232C Level (V)	
		Mark/OFF	Space/ON
TxD	OUT	-5 to -15	+5 to +15
RxD	IN	-3 to -15	+3 to +15
RTS	OUT	-5 to -15	+5 to +15
CTS	IN	-3 to -15	+3 to +15

8.1.3. Pin Assignment

Signals	Pin	Remarks
NC	1	
TxD	2	
RxD	3	
-	4	Jumper to pin 6
GND	5	
-	6	Jumper to pin 4
CTS	7	
RTS	8	
NC	9	

Connector: D-sub 9-pin female

8.1.4. Interface Circuit

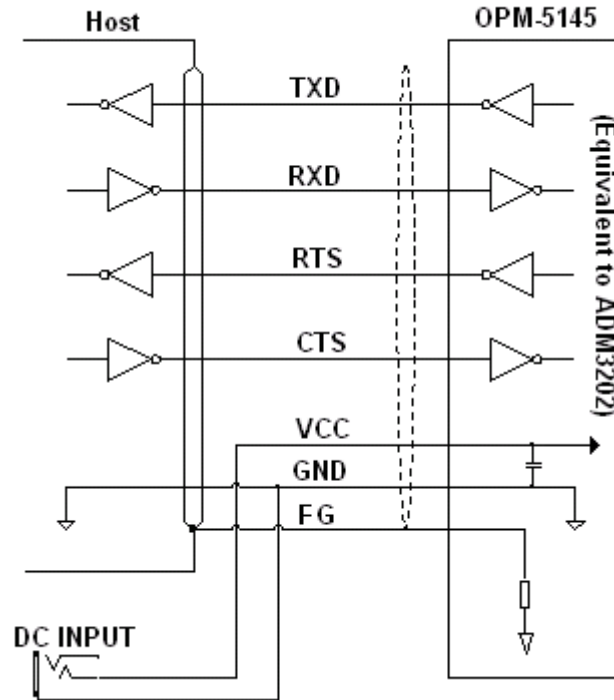

Figure 7: Interface circuit (RS-232C)

8.1.5. Character Format

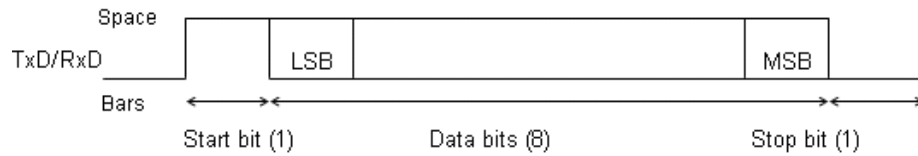

Figure 8: Character format (same for both sending and receiving)

8.1.6. Communication Format

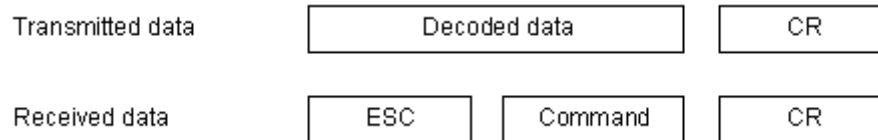

Figure 9: Communication format

8.1.7. Handshaking

Select handshaking options using the menu or command listed below.

Handshaking	Menu/Command
No handshake	P0
BUSY/READY	P1
MODEM	P2
ACK/NAK	P3
ACK/NAK NO RESPONSE	P4

a) No Handshaking

The scanner attempts the communication regardless of the state of the host computer.

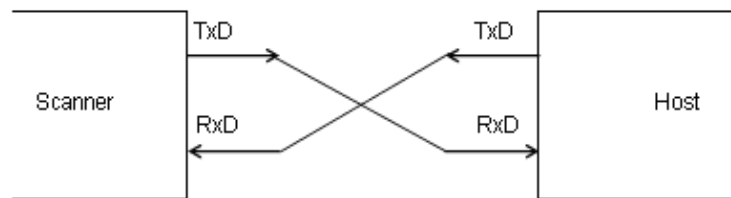

Figure 10: No handshaking

b) BUSY/READY

The scanner and the host computer notify each other of their state and whether they can receive data with BUSY/READY through an RTS line. They can communicate state to each other through a CTS line when connected as in the following figure.

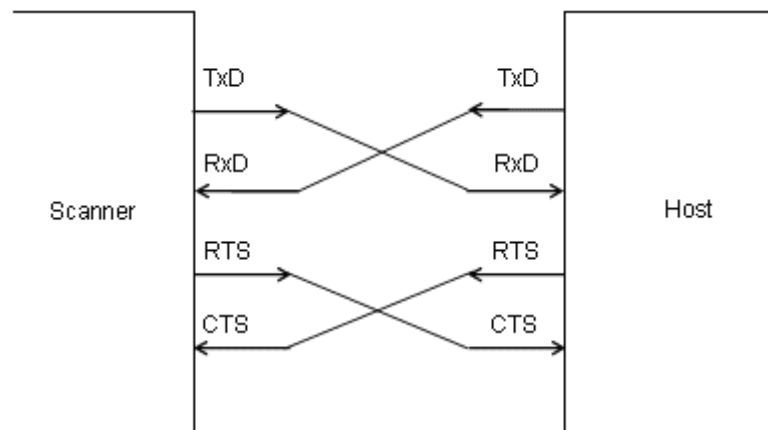

Figure 11: Busy/Ready communication

The scanner stays ON (is able to receive data) except during certain parts of the process, such as receiving data (buzzer command execution), transmitting data, and menu processing. The scanner checks the CTS line before transmitting data. When it is ON, the scanner transmits data. When it is OFF, the scanner waits for it to turn ON within a set time. The scanner will abort transmission with an error indication (buzzer) when the CTS line

is not ON within a specified period. The Flow Control time-outs are as follows, and the default setting is “indefinitely” (I0).

Flow Control Time Out	Menu/Command
Indefinitely	I0
100 ms	I1
200 ms	I2
400 ms	I3

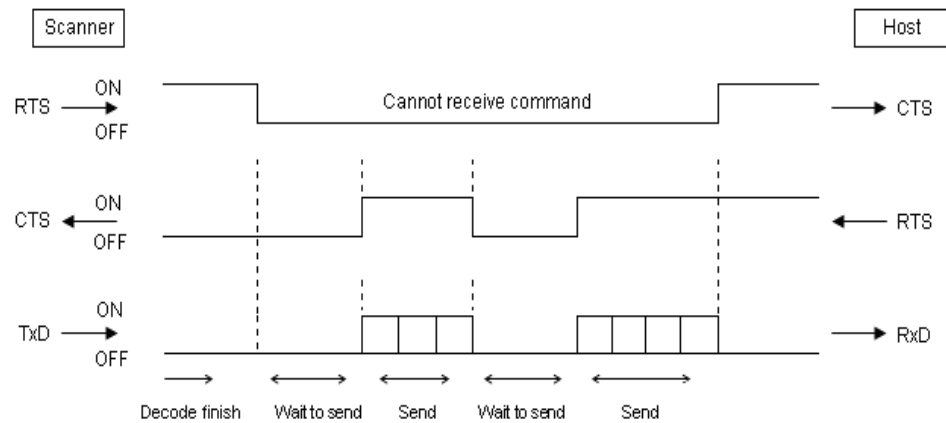

Figure 12: Handshaking Busy/Ready

CTS, TxD Signals Timing

When the CTS line (RTS signal on the host side) is turned OFF while sending a TxD signal, the scanner transmits one character and waits. When the CTS signal is turned ON while transmitting a character, the character will be transmitted.



Figure 13: Signal timing

Note: When using loopback (wire connection) for RTS, CTS line of the scanner in this setting, *No Handshake* is not enabled.

c) MODEM

The scanner turns RTS line ON before transmitting data. Other processes are the same as BUSY/READY.

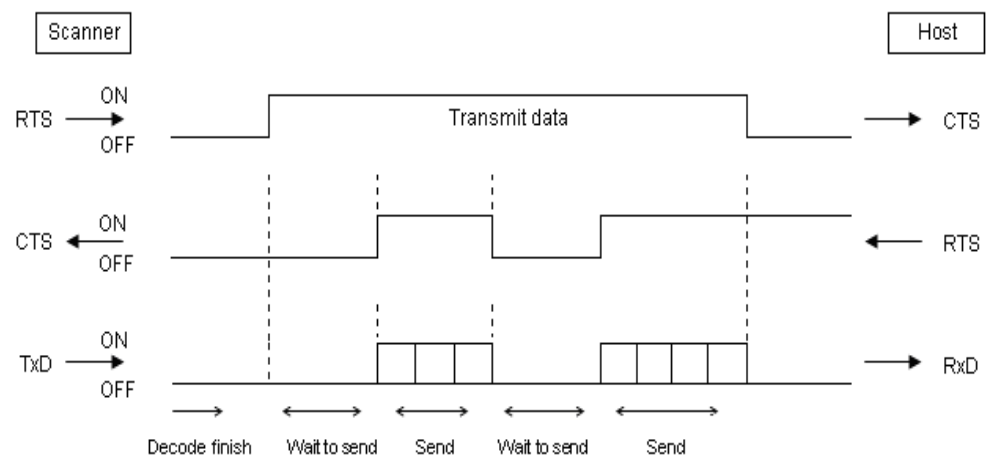

Figure 14: Handshaking: Modem mode

d) ACK/NAK

After data has been transmitted, the scanner expects to receive one of the following responses from the host:

ACK response—Action: The scanner completes transmission with the good-read buzzer and returns to the initial state.

NAK response—Action: The scanner sends the data again and waits for the response from the host.

DC1 response—Action: The scanner returns to waiting for the trigger, if it has a trigger (the initial state).

None response—Action: The scanner sounds the error buzzer and returns to the initial state.

ACK/NAK timeout can be set as follows using the menu or commands.

- I4: Indefinitely (default)
- I5: 100 ms
- I6: 500 ms
- I7: 1000 ms

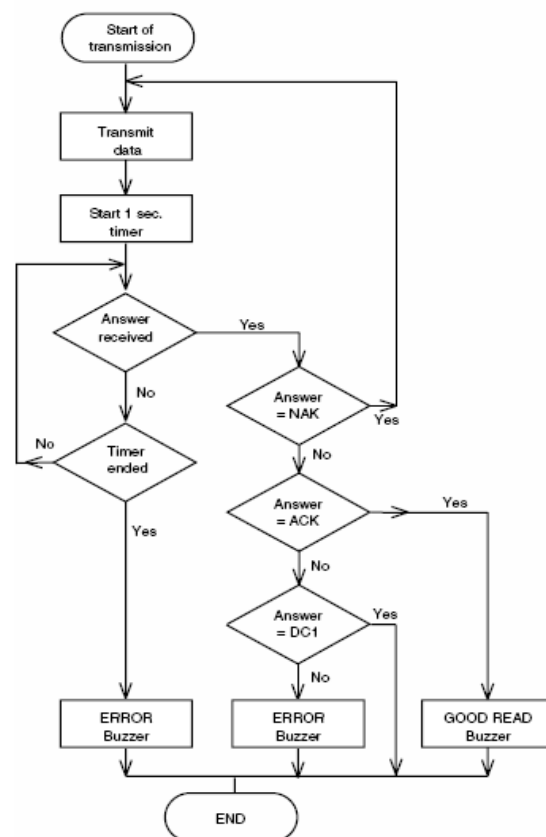

Figure 15: Handshaking: ACK/NAK

e) ACK/NAK NO RESPONSE

When no response from the host is received within the setting time, the scanner assumes an ACK response, and returns to the initial state without the error buzzer. The other actions are the same as ACK/NAK.

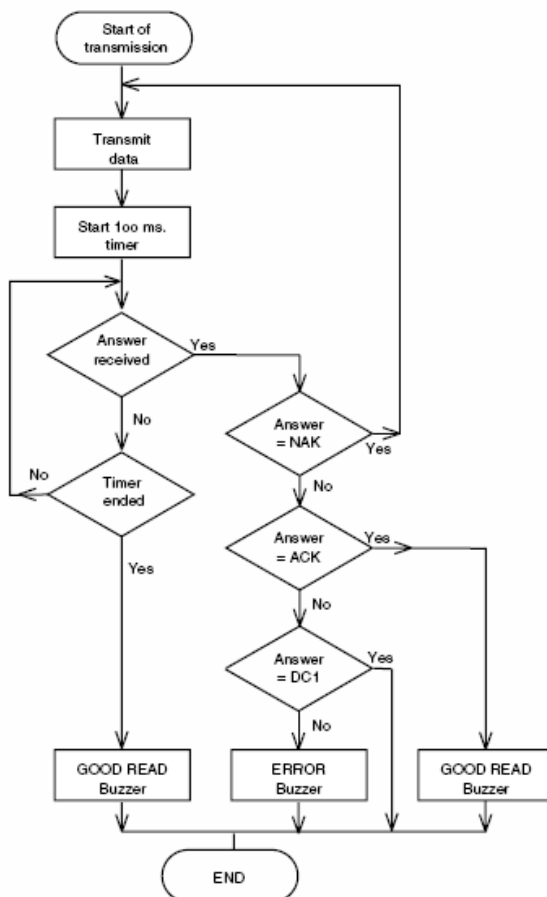

Figure 16: Handshaking: ACK/NAK—No response

8.2. USB Interface Specifications

8.2.1. Connector

a) USB "A" connector

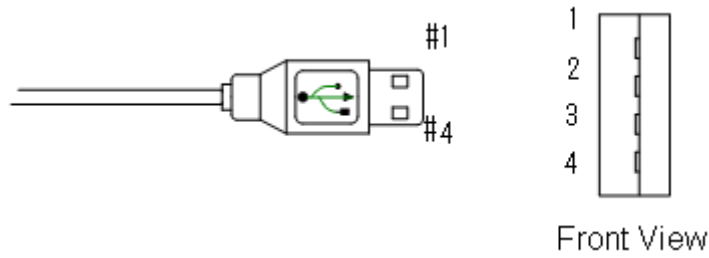

Figure 17: USB "A" connector

Contact Number	Signal Name	Notes
1	VCC	Power signal
2	-DATA	
3	+DATA	
4	GND	

8.2.2. Interface Circuit

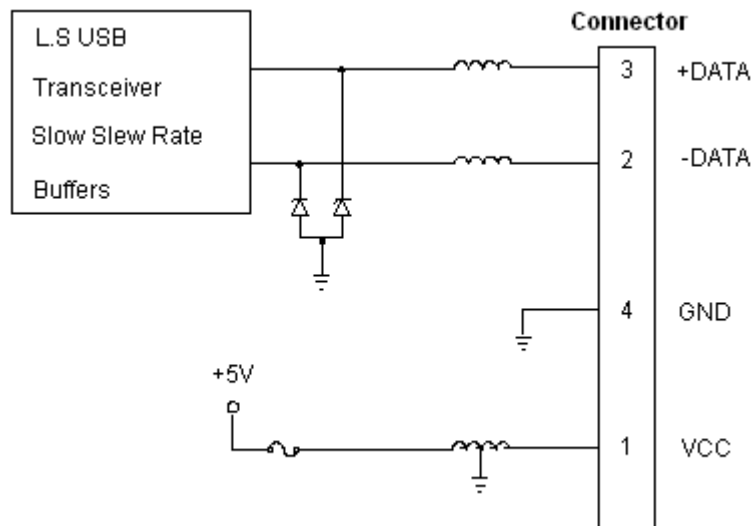

Figure 18: Interface circuit (USB)

8.3. DOS/V Wedge Interface Specification

8.3.1. Connectors

a) DOS/V Host Side

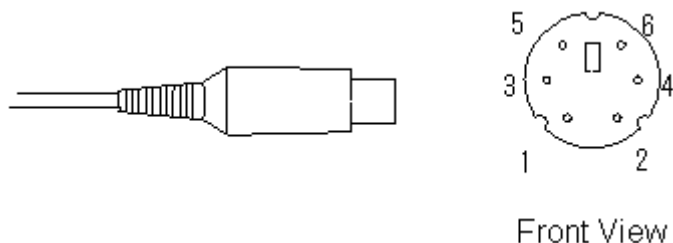

Figure 19: Wedge connector (host side)

Contact Number	Signal Name	Notes
1	CPU DATA	
2	KEY DATA	
3	GND	
4	VCC	Power signal
5	CPU CLOCK	
6	KEY CLOCK	

b) DOS/V Keyboard Side

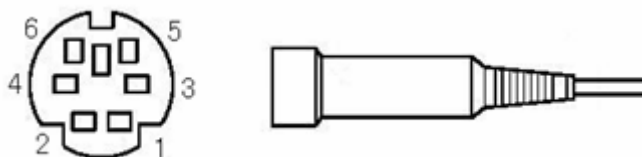

Figure 20: Wedge connector (keyboard side)

Contact Number	Signal Name	Notes
1	KEY DATA	
2	OPEN	
3	GND	
4	VCC	
5	KEY CLOCK	
6	OPEN	

c) DOS/V Side

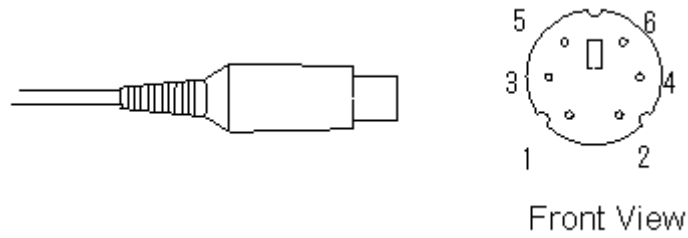

Figure 21: Wedge connector (DOS/V side)

Contact Number	Signal Name	Notes
1	CPU DATA	
2	OPEN	
3	GND	
4	VCC	
5	CPU CLOCK	
6	OPEN	

Note: To connect a PS2 port that supports both a mouse and a keyboard, please use the Y cable that is packaged with the scanner.

9. Cable and Connector

9.1. Cables

(Standard specification)

Type:	Straight (with power jack – RS-232C, DOS/V Wedge only)
Diameter:	φ3.8 mm (main cable), φ3 mm (AC adapter cable)
Length:	2000 ±50 mm (excluding main cable and connector) 250 ±20 mm (excluding AC adapter cable and jack)
Cores:	8 insulated wires, 1 conductive wire (USB interface cable)
Weight:	Approximately 85 g max. (excluding connector)

9.1.1. RS-232C

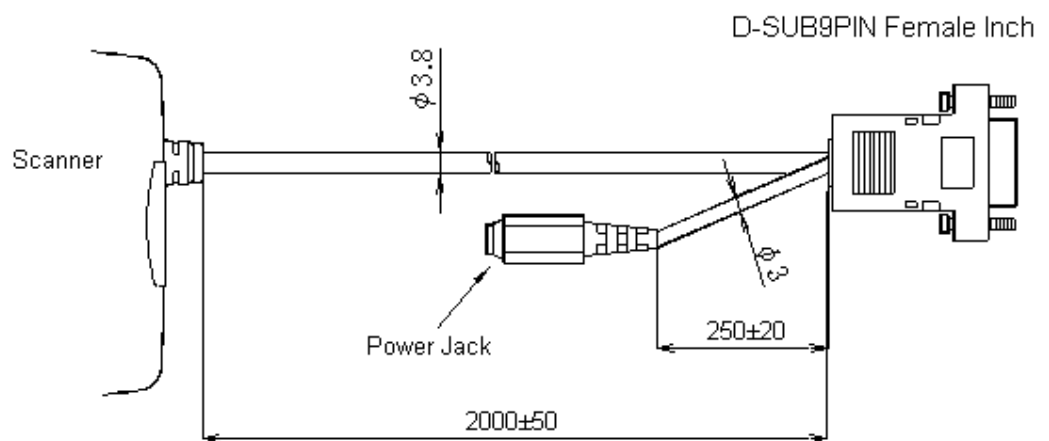

Figure 22: RS-232C cable

9.1.2. USB Cable

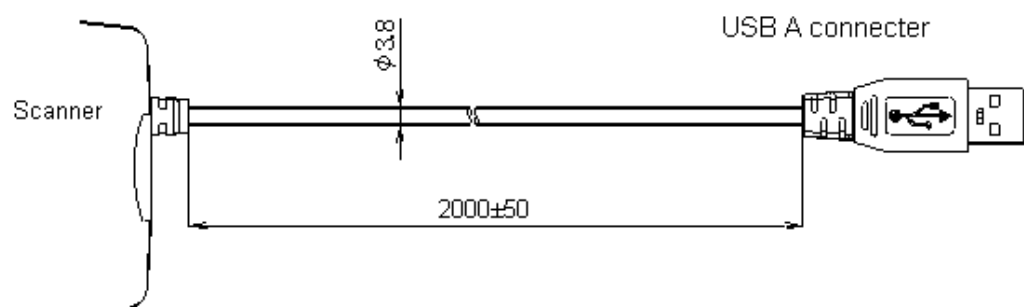

Figure 23: USB cable

9.1.3. DOS V/Wedge Cable

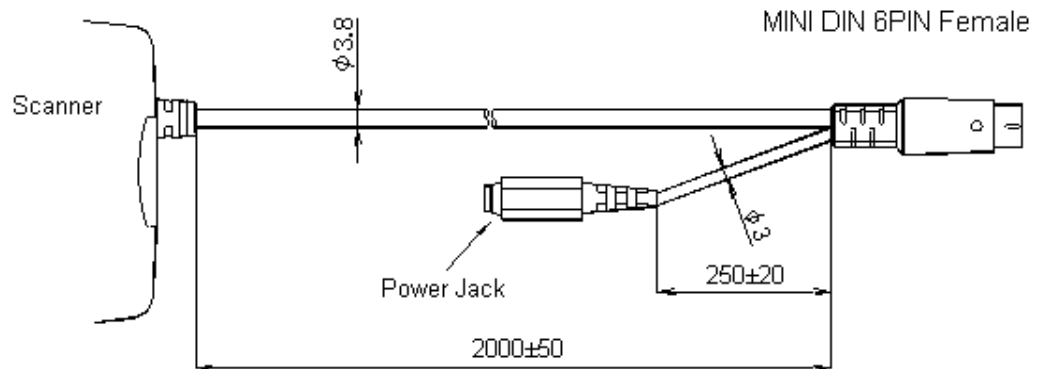

Figure 24: Wedge cable

9.2. Connectors

RS-232C interface:	D-Sub 9-pin (female) connector
DOS/V Wedge interface:	Mini-DIN 6-pin (female) connector
USB interface:	USB-A connector

10. Default Settings

10.1. Set Default Interface

Scan the following menu barcodes to return to the default settings.



RS-232C

Functions	Menu labels	Menu codes
SET		ZZ
RS-232C		U2
END		ZZ





USB-HID

Functions	Menu labels	Menu codes
SET		ZZ
USB-HID		SU
END		ZZ





USB-VCP

Functions	Menu labels	Menu codes
SET		ZZ
USB-VCP		C01
END		ZZ

Wedge (with keyboard)

Functions	Menu labels	Menu codes
SET		ZZ
AT-Wedge		UB
With keyboard		KM
END		ZZ

Wedge (without keyboard)

Functions	Menu labels	Menu codes
SET		ZZ
AT-Wedge		UB
Without keyboard		KL
END		ZZ

10.2. Default Settings 1: Readable Codes

Symbology	Read	Transmit Code Length	Transmit CD	Calculate CD	Set Prefix	Set Suffix	Other
UPC-A	■	X	■	■	-	CR	
UPC-A Add-on	X	X	■	■	-	CR	
UPC-E	■	X	■	■	-	CR	
UPC-E Add-on	X	X	■	■	-	CR	
EAN-13	■	X	■	■	-	CR	
EAN-13 Add-on	X	X	■	■	-	CR	
EAN-8	■	X	■	■	-	CR	
EAN-8 Add-on	X	X	■	■	-	CR	
Chinese Post	X	X	■	X	-	CR	
Codabar/NW-7	■	X	■	X	-	CR	Not transmit ST/SP
Code 11	X	X	X	■	-	CR	
Code 39	■	X	■	X	-	CR	Not transmit ST/SP
Code 93	■	X	X	■	-	CR	
Code 128	■	X	X	■	-	CR	
EAN-128	X	X	X	■	-	CR	
IATA	■	X	■	X	-	CR	
Industrial2of5	■	X	■	X	-	CR	
Interleaved2of5	■	X	■	X	-	CR	
ISBN Japan code	X	X	■	■			Transmit EAN-13 twice
Matrix2of5	X	X	■	X	-	CR	
MSI/Plessey	■	X	■	■	-	CR	
UK/Plessey	■	X	■	■	-	CR	
S-Code	■	X	■	X	-	CR	
Telepen	■	X	X	■	-	CR	
Tri-Optic	■	X	■	X	-	CR	Not transmit ST/SP

Notes:

- In the “Reading” column, “■” means “Enable reading” and “X” means “Disable reading.”
- In the “Transmit code length” column, “■” means “Transmit code length” and “X” means “Do not transmit code length.”

- In the “Transmit CD” column, “■” means “Transmit check digit” and “X” means “Do not transmit check digit.”
- In the “Calculate CD” column, “■” means “Calculate check digit” and “X” means “Do not calculate check digit”.
- In the “Prefix” column, “-” means “There is no prefix setting”.
- For the Wedge and USB interfaces, there are no suffix settings.
- The output contents for JAN ISBN code depends on the setting of EAN-13. The output result is the same as transmitting EAN-13 twice.

10.3. Default Settings 2: Read Options, Trigger, Buzzer

Item	Default Setting	
Setting the number of characters	Fixed length OFF all codes	
Read mode	Multiple read	
Multiple read reset time	500 ms	
Add-on wait mode	500 ms	
Multiple column read	Disable	
Redundancy	Read 2 times, redundancy = 1	
Intercharacter gap check (NW-7)	Within 0.5 characters	
Read time	2 seconds	
Buzzer duration	100 ms	
Buzzer tone	2.6 kHz	
Buzzer loudness	Maximum	
Good read LED	Indicator duration 200 ms	
Set minimum length	Code 11: 1 character Code 39: 1 character Code 93: 1 character Code 128: 1 character Codabar/NW-7: 5 characters EAN 128: 1 character IATA: 5 characters	Industrial 2of5: 5 characters Interleaved 2of5: 6 characters MSI/Plessey: 3 characters UK/Plessey: 2 characters S-Code: 5 characters Telepen: 5 characters

11. Serial Number

The serial number shown below is affixed to the scanner.

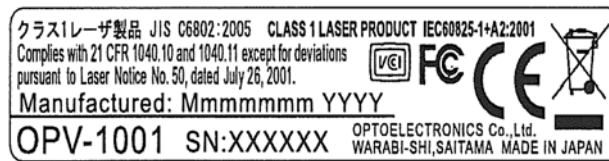
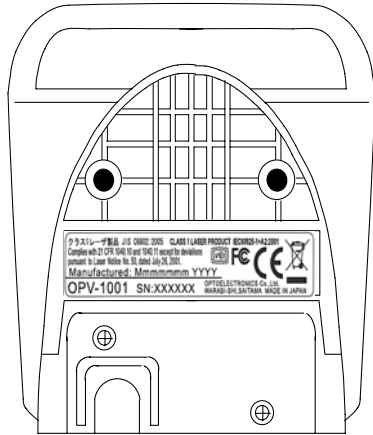

Figure 25: Serial number diagram

12. Packaging Specifications

Put the scanner in a protective foam bag and place it in an individual packing box with the accessories.

Size of the package (after assembly): 165 (W) X 255 (D) X 150 (H) mm

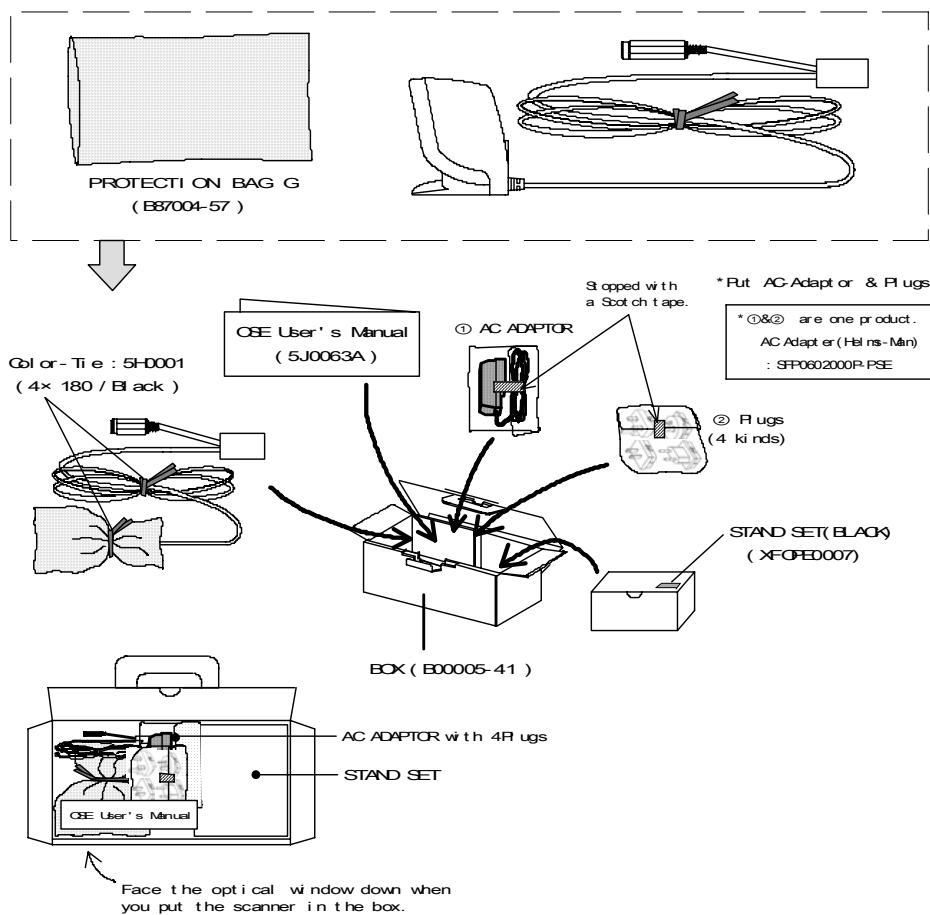

Figure 26: Individual packaging diagram

12.1. Accessory Specifications

The following table shows a list of accessories for each model.

Model	AC Adaptor (GP-ACGN13x-K4-2)	Cable (B04061-300)
OPV 1001-RS-232C	Yes	N/A
OPV 1001-USB	N/A	N/A
OPV 1001-Wedge	Yes	Yes

12.2. Collective Packaging Specification

Put 20 single packages into the packing box.

Size of the package (after assembly): 530 (W) X 850 (D) X 325 (H) mm

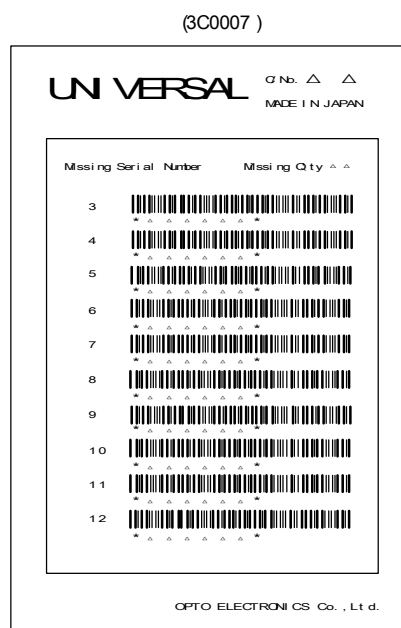
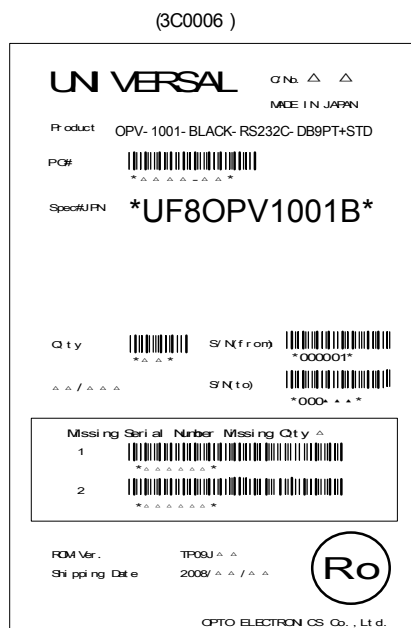
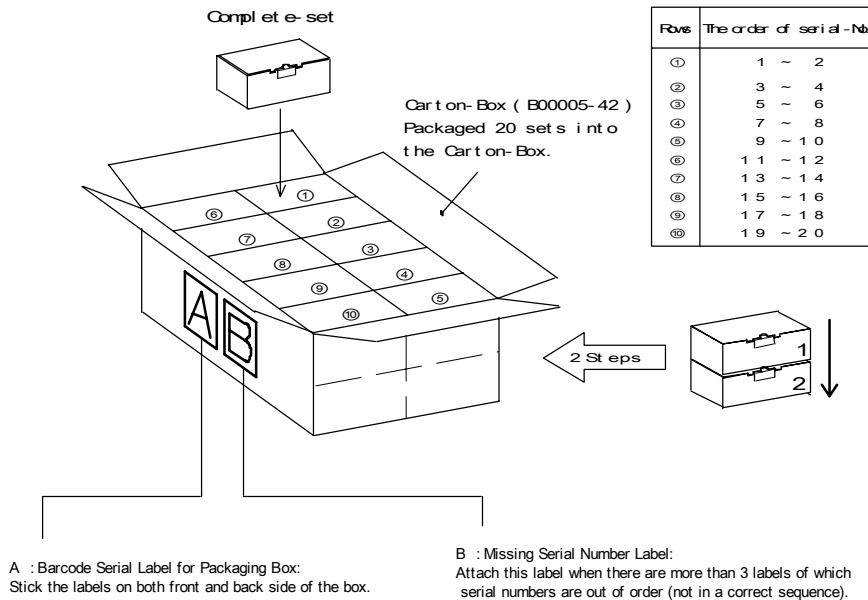

Figure 27: Collective packaging

Note: The “RO” mark labeled on the package tray or package box guarantees that the applicable product has passed our test of RoHS restrictions compliance (the restriction of the use of certain hazardous substances in electrical and electronic equipment, 2002/95 EC). However, this document does **not** have any legal weight in the European Union.

13. Durability

13.1. Static Electricity

Air discharge:	±8 kV max. (No malfunction) ±15 kV max. (No destruction)
Contact discharge:	±4 kV max. (No malfunction) ±8 kV max. (No destruction)
Measurement environment:	Use electrostatic testing device compliant with IEC 61000-4-2
Discharge resistance:	330 Ω
Capacitor charging:	150 pF

13.2. Shock

13.2.1. Drop Test (without packaging)

No malfunction occurred after the following drop test.

Drop Test: Drop the scanner from a height of 100 cm onto a concrete floor (three times on each of 6 sides).

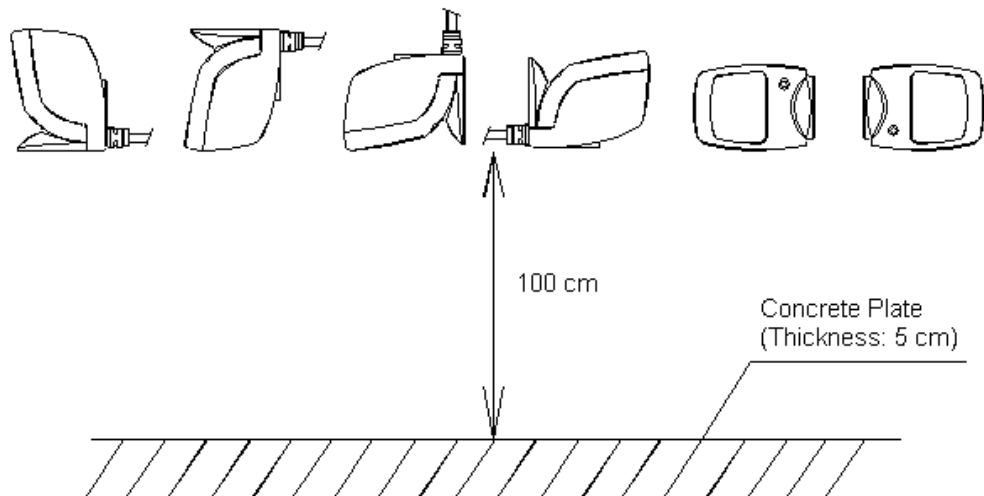

Figure 28: Drop test

13.2.2. Drop Test (with individual packaging)

No malfunction occurred after the following drop test.

Drop Test: Drop an individually packaged scanner from a height of 100 cm onto a concrete floor once on its 1 corner, 3 edges, and 6 sides (10 total drop tests).

13.3. Vibration Strength

No malfunction occurred after the following vibration test.

Vibration test: Increase the frequency of the vibration from 10 Hz to 100 Hz with accelerated velocity 19.6 m/s^2 (2 G) for 60 minutes in non-operating state. Repeat this routine in each X, Y, Z direction once for 60 minutes each.

13.4. Cable Strength

No malfunction occurred after the following cable strength test.

Affix the scanner to an immovable object, then pull it using a force of 2.5 kgf for 1 second. Carry out this test 20 times.

13.5. Cable Bending Test

No malfunction occurred after the following cable bending test.

Bending test: Affix the scanner to a flat surface and attach a weight of 250 grams. Swing the cable back and forth at an angle of 60 degrees. Repeat 500,000 times.

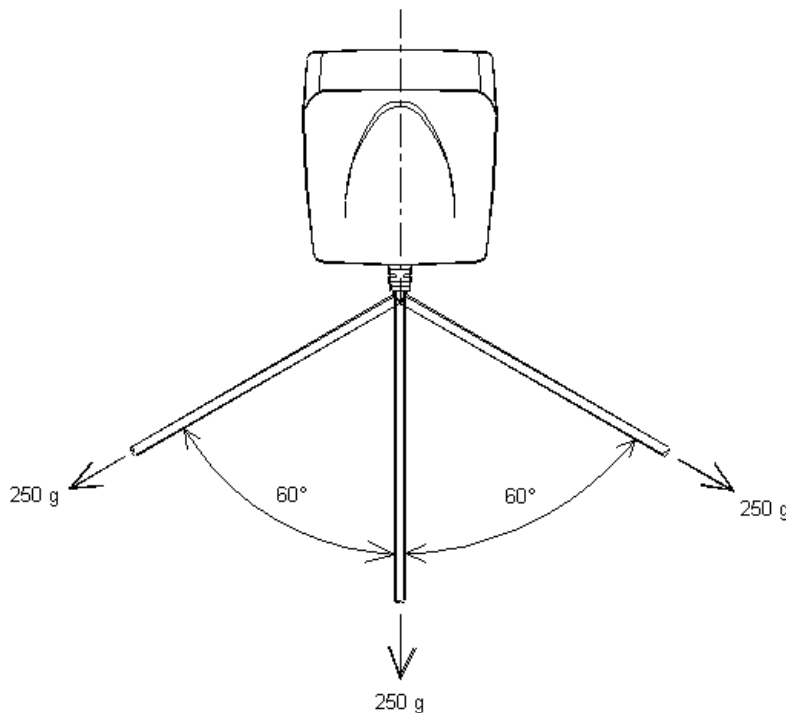

Figure 29: Cable tail bending test

14. Reliability

MTBF (Mean Time Between Failures) of this product except for the laser diode and the mirror motor scan unit is 20,000 hours.

Life cycle of the laser diode is 10,000 hours and that of the mirror motor scan unit is also 10,000 hours.

The estimate of MTBF and product life cycle is based on standard operation of the product within the recommended temperature range and without extreme electronic or mechanical shock.

15. Trigger and Read Options

The OPV 1001 has read and trigger settings as follows:

15.1. Trigger Modes

- Disabled: When this option is selected, the reader will stay on all the time.
- Enabled: After receiving a trigger signal, the barcode reader will turn on and the read cycle starts. The reader will stay on for a time as set in 'Read time options'. The trigger signal can be initiated in the following ways:
 - Manual mode: When the trigger is depressed, the read cycle starts.
 - Auto trigger mode: The read cycle automatically starts when a trigger signal is received via sensor detection.
 - Serial mode: The read cycle starts for a time as set in 'Read time options' after a serial command (<ESC>Z<CR>) is received.
 - Hardware mode: After an electrical pulse (low), the read cycle starts for a time as set in 'Read time options' and behaves as if the trigger is continuously depressed.

15.2. Read modes

- Single read mode: When a symbol has been decoded, the reader will be turned off. The reader must be triggered again to read another symbol. This option and 'Disable trigger' cannot be programmed at the same time.
- Multiple read mode: When a symbol has been decoded, the reader will stay on for a time (set by 'Read time options') or indefinitely, if the trigger switch has been disabled. The same symbol can only be decoded again after the symbol has not been detected for a set number of scans.
- Continuous read mode: The reader will produce as much data as it can decode even if it is reading the same symbol. This mode is mainly used for demonstration and diagnosis.

Conditions

Moving speed:	0.6 m/s
Environmental temperature and humidity:	Room temperature and humidity
Environmental illuminance:	100 to 20,000 lx
Conditions for the auto trigger:	Slide the color sample "Cool Gray-7U" (PANTONE) onto the basic color sample "Black on Black" (PANTONE). Slide the color sample "Black on Black" onto the basic color sample "Cool Gray-7U".

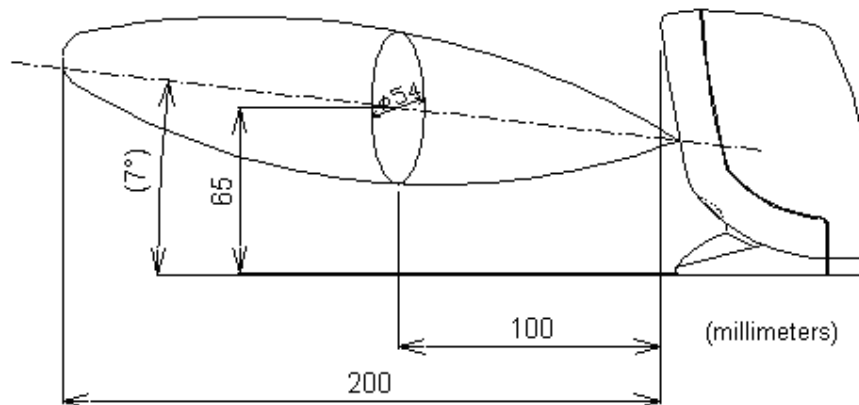

Figure 30: Auto-trigger detection area

16. Trigger and Read Settings

16.1. Auto Trigger Enable/Disable Settings

Use the following settings to enable or disable the auto trigger. (Auto trigger is disabled by default).

To enable auto trigger, scan “ZZ”, “+I” and “ZZ” in that order.







To disable auto trigger, scan “ZZ”, “+F” and “ZZ” in that order.

Functions	Menu labels	Menu codes
SET		ZZ
Disable auto trigger		+F
Enable auto trigger		+I
END		ZZ



17. Power Saving

The motor options are only applicable for selected laser bar code readers and with trigger enabled. If the read time is expired, the motor can be switched OFF. When the trigger is activated, the motor is switched ON again. To reduce the start-up time of the motor, the motor can be configured to half speed in idle mode. The Auto shutoff time can be configured between 1 and 9999 seconds, by reading 1 up to 4 direct input numeric characters from chapter: String options. A value of 0 (default) means that the barcode reader enters the idle state if the read time has expired.

17.1. Motor speed

Functions	Menu labels	Menu codes
SET		ZZ
Motor half speed when idle		BBA
Disable motor when idle		4Z
Enable motor when idle		4Y
Disable trigger		S7
Enable trigger		S8
END		ZZ

17.2. Auto Shut-off Time





Functions	Menu labels	Menu codes
SET		ZZ
Auto shut-off time		BBB
Direct input numeric (set time for power saving)	Use direct input labels	Q0 – Q9
END		ZZ

The enabled time for power saving can be set from 0 to 9999 seconds. Use the direct input numeric 0 to 4 digits after BBB to set the time.





Example:

0 second	“BBB” or “BBB” + “Q0”
1 seconds	“BBB” + “Q1”
12 seconds	“BBB” + “Q1” + “Q2”
123 seconds	“BBB” + “Q1” + “Q2” + “Q3”
1234 seconds	“BBB” + “Q1” + “Q2” + “Q3” + “Q4”
9999 seconds	“BBB” + “Q9” + “Q9” + “Q9” + “Q9”
Disable power saving mode	“ZZ” + “BBB” + “ZZ”

17.3. Power Saving 2 (Motor Rotation—1/2)

Functions	Menu labels	Menu codes
SET	 z z	ZZ
Motor half speed when idle	 B B A	BBA
Enable motor when idle	 4 Y	4Y
END	 z z	ZZ

17.4. Power Saving 3 (Motor Rotation—Stop)

Functions	Menu labels	Menu codes
SET	 z z	ZZ
Disable motor when idle	 4 z	4Z
Enable motor when idle	 4 Y	4Y
END	 z z	ZZ

The power mode transition of Motor / Laser in each setting combination (7 total) is shown below.

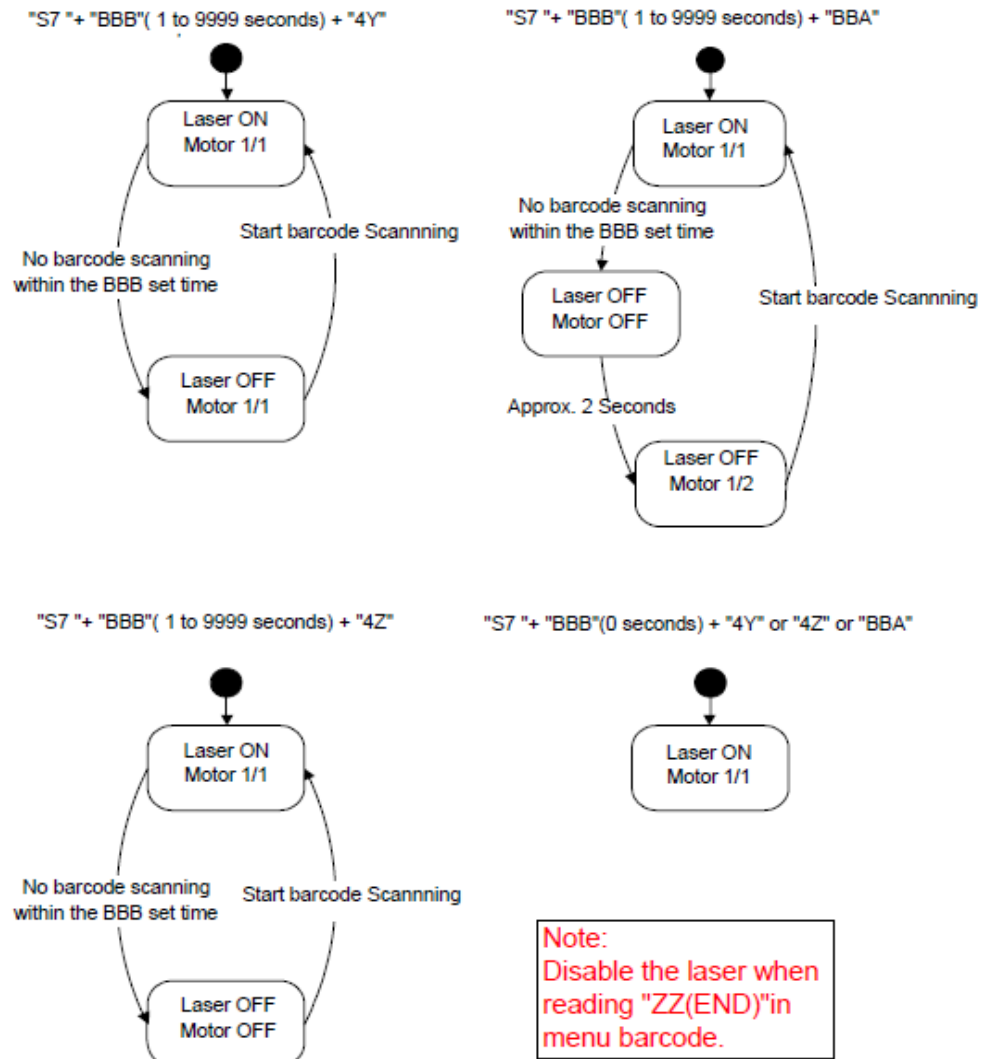

Figure 31: Menu code combinations (part 1)

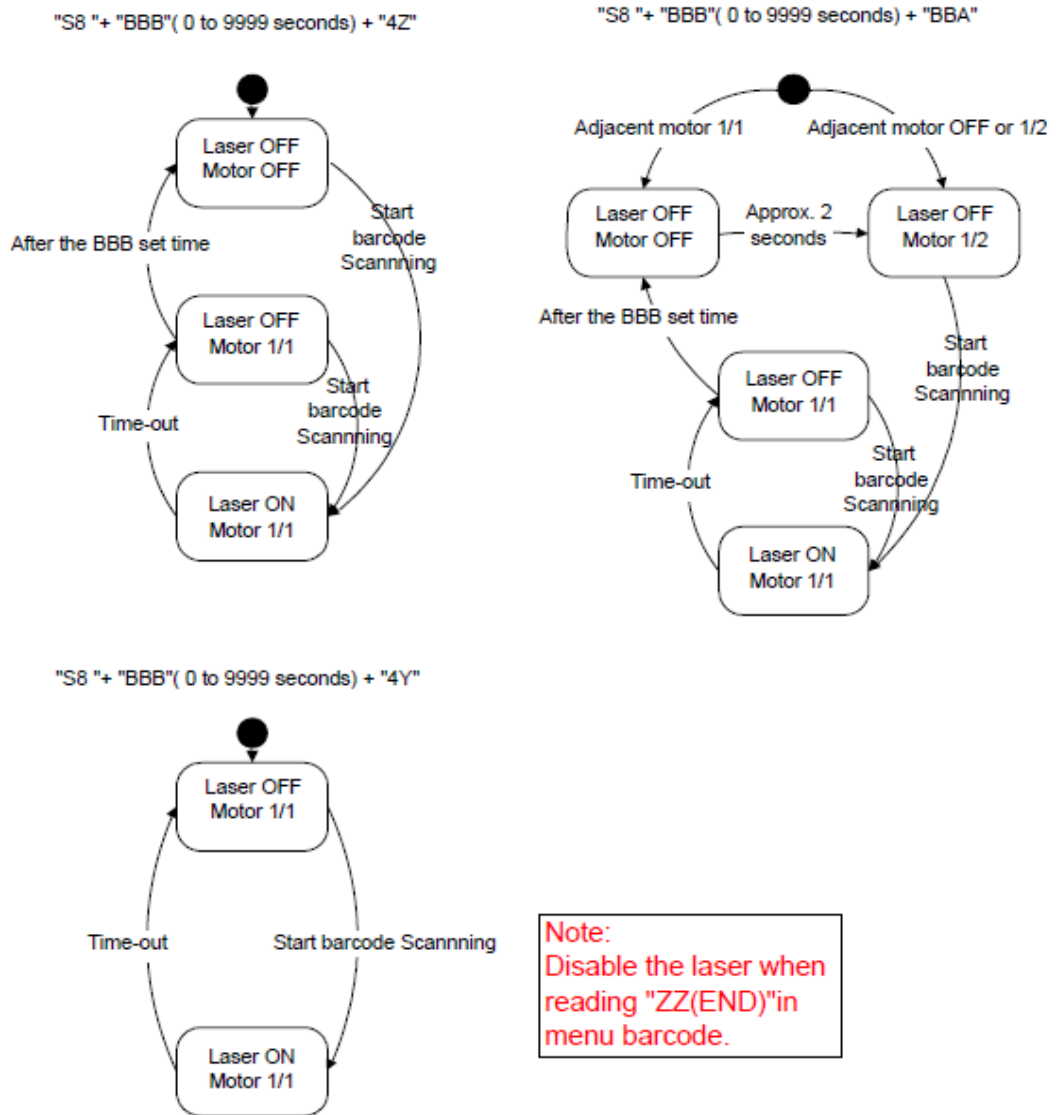

Figure 32: Menu code combinations (part 2)

18. Regulatory Compliance

18.1. Laser Safety

The scanner emits laser beams.

JIS C6802: 2005: Laser class 1

IEC 825-1/EN 60825-1: Laser class 1

FDA CDRH Laser class 1. Complies with 21 CFR 1040.10 and 1040.11 except for deviations pursuant to laser notice No. 50 dated June 24, 2007.

Class 1 laser devices are not considered to be hazardous when used for their intended purpose. Avoid staring into the laser beam.

18.2. Product Safety

EN60950-1: 2001

IEC60950-1: 2001

18.3. EMC

EN55022

EN55024

VCCI Class B: This is a Class B product, to be used in a domestic environment based on the Technical Requirement of the Voluntary Control Council for Interference from Information Technology Equipment (VCCI). If this is used near a radio or television receiver in a domestic environment, it may cause radio interference. Please install and use the equipment according to the instruction manual.

FCC Part 15 Subpart B Class B: This device complies with part 15 of the FCC Rules. Operation is subject to the following two conditions: (1) this device may not cause harmful interference, and (2) this device must accept any interference received, including interference that may cause undesired operation.

18.4. RoHS

RoHS: The restriction of the use of certain hazardous substances in electrical and electronic equipment, 2002/95 EC.

19. Safety

Handle this product carefully. Do not deliberately subject it to any of the following.

19.1. Shock

Do not throw or drop the scanner.

Do not place heavy objects on the cables.

19.2. Temperature Conditions

Do not use the scanner at temperatures outside the specified range.

Do not pour boiling water on the scanner.

Do not throw the scanner into the fire.

Do not forcibly bend the cables at low temperatures.

19.3. Foreign Materials

Do not immerse the scanner in liquids.

Do not subject the scanner to chemicals.

19.4. Other

Do not plug/unplug the connectors before disconnecting the power.

Do not disassemble this product.

Do not place the product near a radio or a TV receiver, as the scanner may cause reception problems.

The scanner may be damaged by voltage drops.

The scanner may not perform properly in environments when placed near a flickering light, such as a computer monitor, television, etc.

20. Mechanical Drawing

20.1. OPV 1001 (without stand)

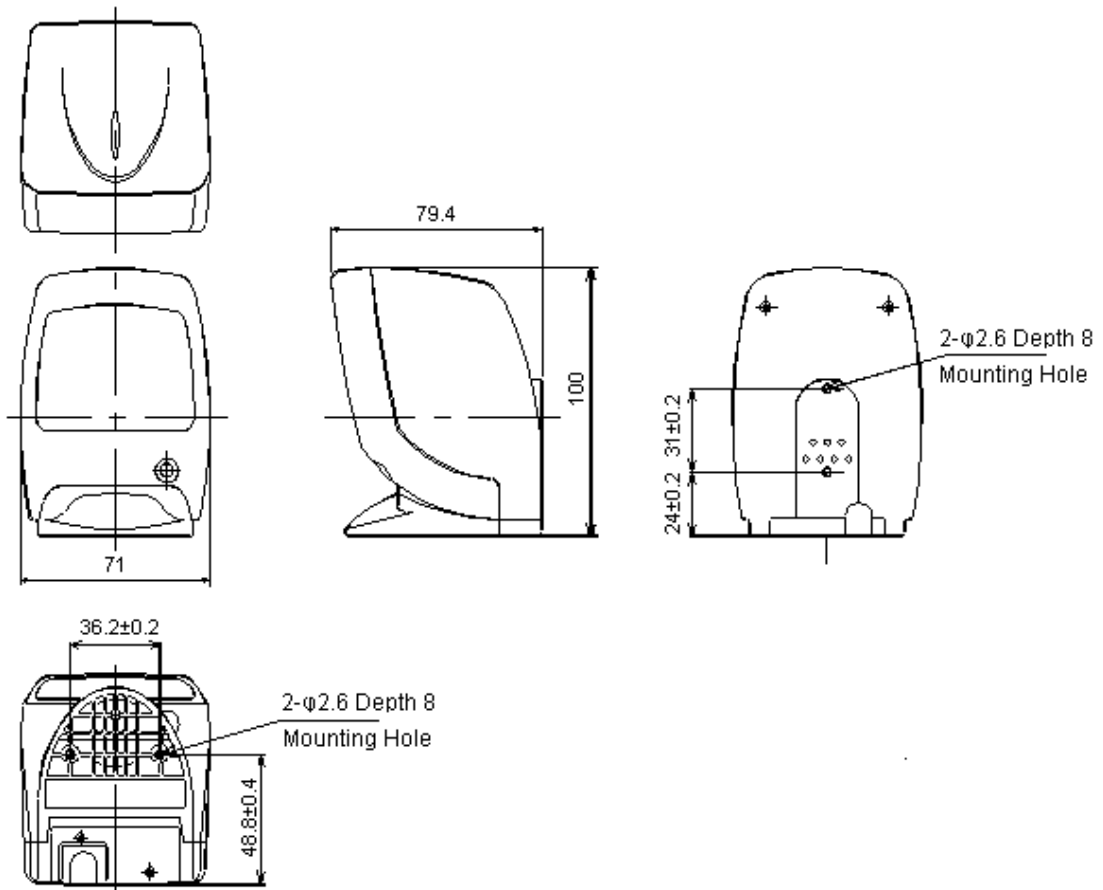

Figure 33: Mechanical drawing (without stand)

20.2. OPV 1001 (with stand)

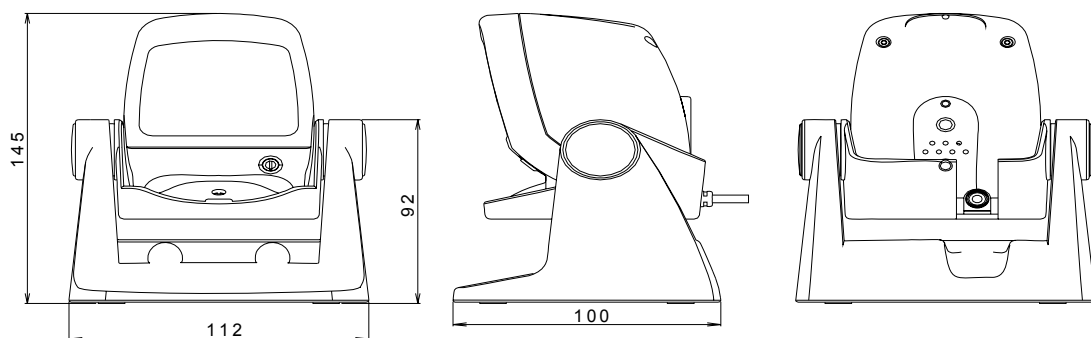

Figure 34: Mechanical drawing (with stand)