

**OPTICON**

Barcode Data Collector

# OPL 9712



The OPL 9712 data collector uses barcode laser scanning technology and uses Bluetooth for communication.

## Specifications Manual

All information subject to change without notice.

## Document History

<b>Model Number:</b>	OPL 9712	<b>Specification Number:</b>	SS06071
<b>Edition:</b>	1A	<b>Original Spec Number:</b>	SS06050
<b>Date:</b>	2007-02-05		

## Copyright 2007 Opticon. All rights reserved.

This manual may not, in whole or in part, be copied, photocopied, reproduced, translated or converted to any electronic or machine readable form without prior written consent of Opticon.

## Limited Warranty and Disclaimers

**PLEASE READ THIS MANUAL CAREFULLY BEFORE INSTALLING OR USING THE PRODUCT.**

## Serial Number

A serial number appears on all Opticon products. This official registration number is directly related to the device purchased. Do not remove the serial number from your Opticon device. Removing the serial number voids the warranty.

## Warranty

Unless otherwise agreed in a written contract, all Opticon products are warranted against defects in materials and workmanship for two years after purchase. Opticon will repair or, at its option, replace products that are defective in materials or workmanship with proper use during the warranty period. Opticon is not liable for damages caused by modifications made by a customer. In such cases, standard repair charges will apply. If a product is returned under warranty and no defect is found, standard repair charges will apply. Opticon assumes no liability for any direct, indirect, consequential or incidental damages arising out of use or inability to use both the hardware and software, even if Opticon has been informed about the possibility of such damages.

## Packaging

The packing materials are recyclable. We recommend that you save all packing material to use should you need to transport your data collector or send it for service. Damage caused by improper packaging during shipment is not covered by the warranty.

## Trademarks

Trademarks used are the property of their respective owners.

Opticon Inc. and Opticon Sensors Europe B.V. are wholly owned subsidiaries of OPTOELECTRONICS Co., Ltd., 12-17, Tsukagoshi 4-chome, Warabi-shi, Saitama, Japan 335-0002. TEL +81-(0) 48-446-1183; FAX +81-(0) 48-446-1184

---

## SUPPORT

### USA

Phone: 800-636-0090

Email: [support@opticonusa.com](mailto:support@opticonusa.com)

Web: [www.opticonusa.com](http://www.opticonusa.com)

### Europe

Email: [support@opticon.com](mailto:support@opticon.com)

Web: [www.opticon.com](http://www.opticon.com)

---

# Contents

- 1. Abstract ..... 6**
- 2. Overview ..... 6**
- 3. Physical Features ..... 7**
  - 3.1. Dimensions ..... 7
  - 3.2. Weight ..... 7
  - 3.3. Color ..... 7
- 4. Environmental Specifications ..... 7**
  - 4.1. Operating Temperature and Humidity ..... 7
  - 4.2. Storage Temperature and Humidity ..... 7
  - 4.3. Ambient Light Immunity ..... 8
- 5. Controls ..... 9**
- 6. Electrical Specifications ..... 9**
  - 6.1. Main Battery ..... 9
  - 6.2. Battery Operating Time and Charging Time ..... 9
- 7. Optical Specifications ..... 10**
  - 7.1. Laser Scan Specifications ..... 10
- 8. Technical Specifications ..... 10**
  - 8.1. Print Contrast Signal (PCS) ..... 10
  - 8.2. Minimum Resolution ..... 10
  - 8.3. Scan Area and Resolution ..... 11
    - 8.3.1. Depth of Field ..... 11
  - 8.4. Pitch, Skew, and Tilt ..... 12
    - 8.4.1. Pitch Angle ..... 12
    - 8.4.2. Skew Angle and Dead Zone ..... 13
    - 8.4.3. Tilt Angle ..... 14
  - 8.5. Curvature ..... 15
- 9. Interface Specifications ..... 16**
  - 9.1. Wireless Interface ..... 16
  - 9.2. IEEE 802.15.4 ..... 17
    - 9.2.1. Radio Equipment ..... 17
    - 9.2.2. Frequency Band ..... 17
  - 9.3. Infrared Transmission (IrDA) ..... 17

- 9.3.1. Specifications ..... 17
- 9.3.2. Transmission Speed ..... 17
- 10. Default Settings ..... 18**
  - 10.1. Default Settings 1: Readable Codes ..... 18
- 11. Serial Number and Labeling ..... 19**
  - 11.1. Serial Number ..... 19
  - 11.2. FCC Label ..... 20
- 12. Packaging Specifications ..... 21**
  - 12.1. Individual Packaging Specification ..... 21
  - 12.2. Accessory Specification ..... 22
  - 12.3. Collective Packaging Specification ..... 22
- 13. Durability ..... 23**
  - 13.1. Shock ..... 23
    - 13.1.1. Drop Test (without packaging) ..... 23
  - 13.2. Vibration Strength ..... 23
  - 13.3. Dust and Drip Proof ..... 24
- 14. Reliability ..... 24**
- 15. Regulatory Compliance ..... 25**
  - 15.1. Laser Safety ..... 25
  - 15.2. Product Safety ..... 25
  - 15.3. EMC ..... 25
  - 15.4. RoHS ..... 25
  - 15.5. R&TTE ..... 25
  - 15.6. Radio Law ..... 26
  - 15.7. State of California: Perchlorate Best Management Practices ..... 26
- 16. Safety ..... 27**
  - 16.1. Shock ..... 27
  - 16.2. Temperature Conditions ..... 27
  - 16.3. Foreign Materials ..... 27
  - 16.4. Other ..... 27
- 17. Mechanical Drawing ..... 28**

## Table of Figures

Figure 1: Ambient Light Immunity .....	8
Figure 2: Depth of field .....	11
Figure 3: Pitch .....	12
Figure 4: Skew and dead zone .....	13
Figure 5: Tilt angle .....	14
Figure 6: Curvature.....	15
Figure 7: Serial number diagram .....	19
Figure 8: FCC label .....	20
Figure 9: Individual packaging.....	21
Figure 10: Labels on individual packaging.....	22
Figure 11: Shock test.....	23
Figure 12: Mechanical drawing.....	28

## 1. Abstract

This manual provides specifications for the OPL 9712 barcode data collector (hereafter referred to as “data collector”).

## 2. Overview

This data collector uses laser technology. To start a scan, press the trigger switch. Do not allow the data collector to directly touch the surface of a barcode when scanning.

Operating the data collector via a trigger switch enables low-power operation and longer battery life.

Supported symbologies:

### Linear (1D)

JAN/UPC/EAN, incl. add-on  
Codabar/NW-7  
Code 11  
Code 39  
Code 93  
Code 128  
GS1-128 (EAN-128)  
GS1 Databar (RSS)  
IATA  
Industrial 2of5  
Interleaved 2of5  
ISBN--ISSN  
Matrix 2of5  
MSI/Plessey  
S-Code  
Telepen  
Tri-Optic  
UK/Plessey

### Postal

Chinese Post  
Korean Postal Authority Code

### 2D

Composite Codes  
MicroPDF417\*  
PDF417\*

\* Requires use of an external library.

Using the built-in clock function, you can add a time stamp to the scanned data.

The OPL 9712 can use a variety of cradles:

- CRD 9723 single-bay cradle (1 x charging, 1 x communication)
- CRD 9723 multi-bay cradle (5 x charging, 1 x communication)
- CRD 9723 multi-bay cradle (5 x charging, 5 x communication)
- CRD 9722 single-bay cradle (1 x charging, no communication)

Applications can be developed for this product using the Software Development Kit (SDK). Software can be developed in the C programming language. These development tools are available as accessories.

### 3. Physical Features

#### 3.1. Dimensions

W 129 mm x D 44 mm x H 22.3 mm

#### 3.2. Weight

105 grams (with lithium-ion batteries installed).

#### 3.3. Color

Gray

### 4. Environmental Specifications

#### 4.1. Operating Temperature and Humidity

Temperature: 0 to 40° C

Humidity: 20 to 85%

#### 4.2. Storage Temperature and Humidity

Temperature: -20 to +60° C

Humidity: 20 to 90%

### 4.3. Ambient Light Immunity

Decoding performance is guaranteed when the range of illumination on a barcode surface is between zero and the following values:

Incandescent light	3,000 lx
Fluorescent light	3,000 lx
Sunlight	50,000 lx

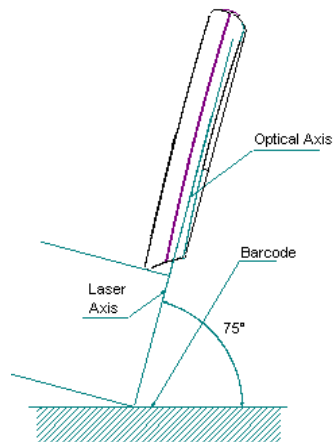

Figure 1: Ambient Light Immunity

#### Conditions

Barcode Sample: OPTOELECTRONICS Test Sample

PCS:	0.9
Resolution:	0.25 mm
Symbology:	8-digit Code 39
Quiet Zone:	10 mm
N/W Ratio:	1:2.5

Direct light or specular reflection light from a source should be prevented from entering the acceptance area.

**Note:**  $\alpha$ ,  $\beta$  and  $\gamma$  respectively represent pitch, skew and tilt. Please see section 8 for how these values are defined.



## 5. Controls

Item	Specifications		Remarks
Controls	MPU	16-bit CISC CPU	Manufactured by Toshiba
	Clock frequency	14.74 MHz	
External memory	Flash ROM	512 KB	For BIOS/AP
	SRAM	512 KB	For WORK/DATA
Display	LCD	Semi-transparent dot matrix LCD	
	DPI	112 x 64 dpi	
	Backlight	Installed	
	Functions	Clock time, battery power, failure notification, function settings	
Clock	Real time clock	Counts year, month, date, hour, minute of the current time and corresponding to leap years	

## 6. Electrical Specifications

### 6.1. Main Battery

The main battery is a lithium-ion secondary battery.

Nominal capacity: 600 mAh

Battery life: rechargeable 300 times

### 6.2. Battery Operating Time and Charging Time

Parameter	Specifications	Notes
Backup battery	3.4 mAh lithium-ion battery	
Current consumption	1 mA or less	At standby
	150 mA or less	When operating
Usable time	24 hours or more	1 scan/5s Without backlight, with Bluetooth communication
	50 hours or more	1 scan/5s Without backlight, no communication
Data hold time	72 hours or more	After main battery discharged

**Note:** Battery life may be shorter than specified above when the quality of the battery pack is degraded.

## 7. Optical Specifications

### 7.1. Laser Scan Specifications

Parameter	Specification	Unit
Light-emitting element	Red laser diode	—
Emission wavelength	650 ±10 (25° C)	nm
Light output	1.0 or less	mW
Scanning method	Bi-directional vibration mirror	—
Scanning speed	100 ±20	scans/s
Scan angle	Scan angle: 54 ±5	°
	Read angle: 44 (Min)	°

**Note:** Refer to chapter 8, “Technical Specifications,” to read about scanning performance.

## 8. Technical Specifications

The conditions for technical specifications are as follows, unless otherwise specified in each section.

### Conditions

Ambient temperature and humidity:	Room temperature (5 to 35° C) Room humidity (45% to 85% RH)
Ambient light:	500 to 900 lx
Background:	Barcode = black Space = white Margin = white Background of label = black

### 8.1. Print Contrast Signal (PCS)

0.45 or higher (over 70% of reflectivity of space and quiet zone).

$$PCS = \frac{\text{Reflectance of white bar} - \text{Reflectance of black bar}}{\text{Reflectance of white bar}}$$

Scanning performance may decline if dirt or scratches mar the optical window. Keep the optical window clean.

### 8.2. Minimum Resolution

0.15 mm

**8.3. Scan Area and Resolution**

**8.3.1. Depth of Field**

The depth of field is measured from the edge of the data collector. The scanning range is within the circular arc centered on the scan origin.

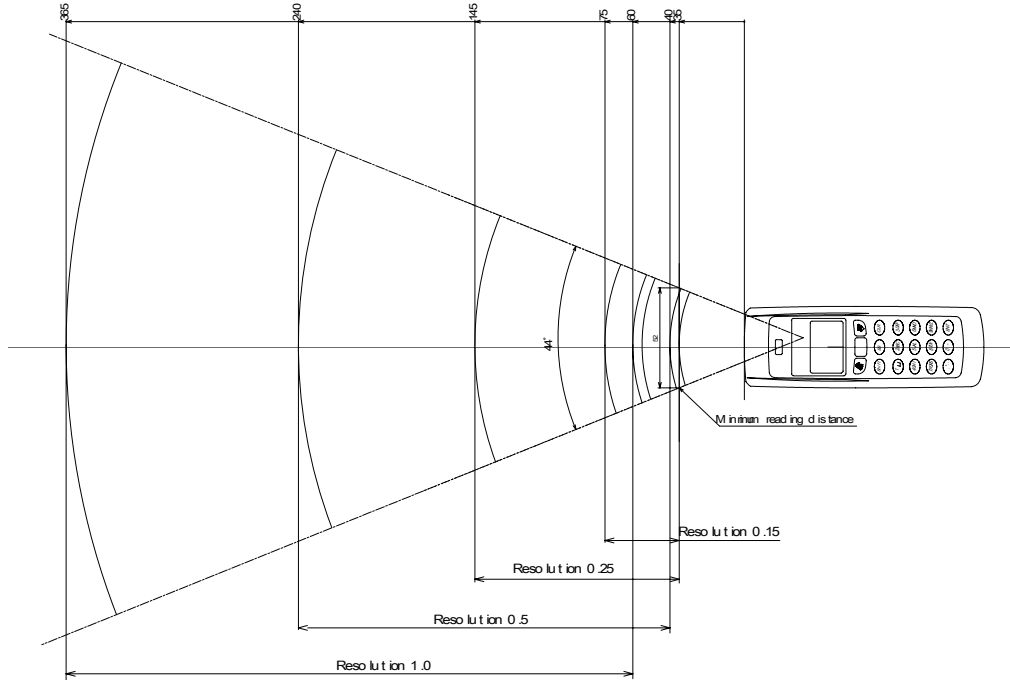

Figure 2: Depth of field

Symbology	Resolution (mm)	Decode Depth (mm)	PCS
Code 39	1.0	60–300	0.9
Code 39	0.5	35–210	0.9
Code 39	0.25	35–120	0.9
Code 39	0.15	35–70	0.9

**Conditions**

Barcode Sample: OPTOELECTRONICS Test Sample

- N/W ratio: 1:2.5
- Angle:  $\alpha = 0^\circ, \beta = 15^\circ, \gamma = 0^\circ$
- Curvature:  $R = \infty$

Resolution	Symbology	PCS	Quiet Zone	Digit
1.0 mm	Code 39	0.9	25 mm	1
0.5 mm	Code 39	0.9	18 mm	3
0.25 mm	Code 39	0.9	10 mm	8
0.15 mm	Code 39	0.9	7 mm	10

Note: dirt or scratches on the mask will degrade scanning performance. Always handle the data collector carefully.

### 8.4. Pitch, Skew, and Tilt

#### 8.4.1. Pitch Angle

$$\alpha = \pm 25^\circ$$

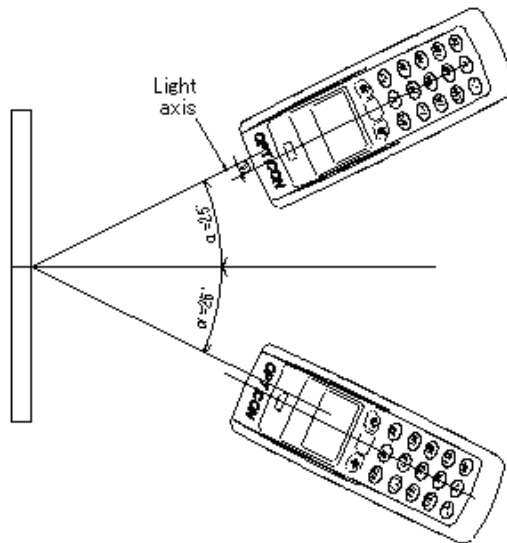

Figure 3: Pitch

#### Conditions

Barcode Sample: OPTOELECTRONICS Test Sample

Distance: 90 mm from the edge of the data collector

Label: **Pitch, Skew Angle**

PCS = 0.9, Resolution = 0.25 mm, Symbology = 9-digit Code 39,  
Quiet Zone = 10 mm, N/W Ratio = 1:2.5

**Dead Zone, Tilt Angle**

PCS = 0.9, Resolution = 0.26 mm, Symbology = 13-digit JAN, Quiet Zone = 10 mm

Angle: Curvature:  $R = \infty$ , Skew Angle =  $\beta + 15^\circ$  (for measuring Pitch Angle and Tilt Angle)

### 8.4.2. Skew Angle and Dead Zone

Skew angle:  $\beta = \pm 50^\circ$  (Excluding dead zone)

Dead zone:  $\beta = \pm 8^\circ$  (There are some areas in which decoding fails due to specular reflection)

(Depth of field: Within 90 mm from the minimum scannable distance).

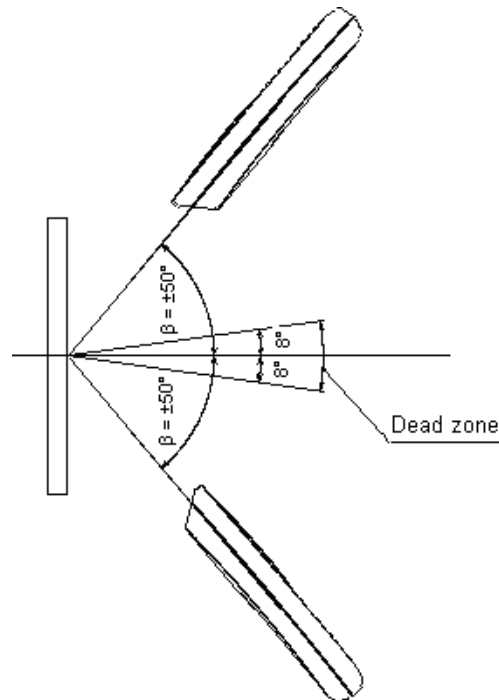

Figure 4: Skew and dead zone

### Conditions

Barcode Sample: OPTOELECTRONICS Test Sample

Distance: 90 mm from the edge of the data collector

Label: **Pitch, Skew Angle**

PCS = 0.9, Resolution = 0.25 mm, Symbology = 9-digit Code 39,  
Quiet Zone = 10 mm, N/W Ratio = 1:2.5

**Dead Zone, Tilt Angle**

PCS = 0.9, Resolution = 0.26 mm, Symbology = 13-digit JAN, Quiet Zone = 10 mm

Angle: Curvature:  $R = \infty$ , Skew Angle =  $\beta + 15^\circ$  (for measuring Pitch Angle and Tilt Angle)

**8.4.3. Tilt Angle**

$$\gamma = \pm 20^\circ$$

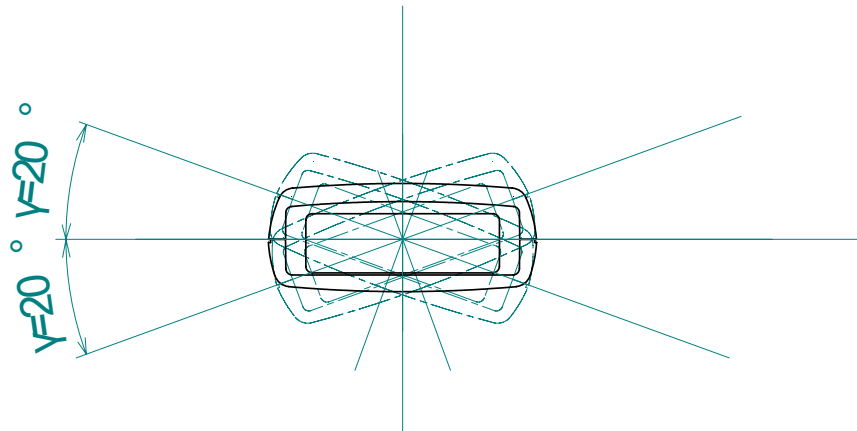
*Figure 5: Tilt angle***Conditions**

Barcode Sample: OPTOELECTRONICS Test Sample

Distance: 90 mm from the edge of the data collector

Label: **Pitch, Skew Angle**PCS = 0.9, Resolution = 0.25 mm, Symbology = 9-digit Code 39,  
Quiet Zone = 10 mm, N/W Ratio = 1:2.5**Dead Zone, Tilt Angle**

PCS = 0.9, Resolution = 0.26 mm, Symbology = 13-digit JAN, Quiet Zone = 10 mm

Angle: Curvature:  $R = \infty$ , Skew Angle =  $\beta + 15^\circ$  (for measuring Pitch Angle and Tilt Angle)

## 8.5. Curvature

With 8-digit JAN/UPC/EAN barcodes, decoding performance is guaranteed when  $R \geq 15$  mm.

With 13-digit JAN/UPC/EAN barcodes, decoding performance is guaranteed when  $R \geq 20$  mm.

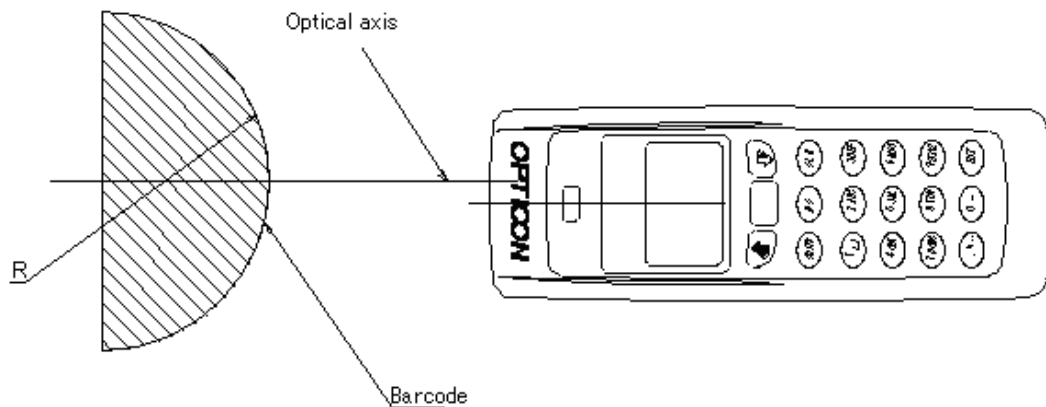

Figure 6: Curvature

### Conditions

Barcode Sample: OPTOELECTRONICS Test Sample

PCS = 0.9, Resolution = 0.26 mm, Quiet Zone = 10 mm

Distance: 90 mm from the edge of the data collector

Angle: Skew Angle  $\beta = +15^\circ$

The scanning range will vary according to the depth of field.

## 9. Interface Specifications

### 9.1. Wireless Interface

Bluetooth® is a registered trademark owned by its proprietor and used by OPTOELECTRONICS Co., Ltd. under license.

Feature	Description
Version 1)	2.0
Supported protocol stack 1)	RF (Radio Frequency Protocol) BB (Base Band Protocol) LM (Link Manager Protocol) L2CAP (Logical Link Control and Adaptation Protocol) SDP (Service Discovery Protocol) RFCOMM (serial port emulation)
Supported profile 1)	DUN (Dial-up Network Profile) SPP (Serial Port Profile)
Communication configuration 2)	1 to 1 One data collector to one host system (Do not connect multiple data collectors to one host system.)
Scanner operating mode while connected to the host system	Master or Slave mode
Security mode	Authentication enabled: These settings can be configured using menu barcodes.
Encryption	Encryption is linked to the authentication setting and cannot be enabled or disabled separately.
Communication range 3)	Approximately 10 meters
Frequency	2400 MHz to 2483.5 MHz
Transmission power	2.5mW (4dBm) or less
Comm. range	10 m
Baud rate	115.2 kbps
Antenna	1/4λ (surface mounted)

#### Notes

1. This product complies with Bluetooth standards. The device that communicates with this product must support the same SPP. For other Bluetooth devices with other profiles we cannot guarantee a connection before the products have been tested.
2. The communication speed and range of the product may vary due to obstacles and radio wave conditions between this product and the device to which it is connected. Conditions on the host device may also affect the communication speed and communication range of the data collector.



3. The prospective distance may vary based on environmental characteristics. Also note the following frequency description.

## **9.2. IEEE 802.15.4**

### **9.2.1. Radio Equipment**

The electromagnetic wave absorption (2.4 GHz) used by this product is also shared by various other devices. Therefore, baud rate and communication distance may be negatively impacted, or their communications may be disconnected, by other devices using the same absorption rate.

Baud rate and communication distance are affected by obstacles, wave conditions, or a device at the other end.

This product is equipped with an antenna. Bringing this product too close to a metallic object may affect communication. Anticipated interference distance is 10 m or less.

### **9.2.2. Frequency Band**

This product uses the 2.4 GHz frequency band. Scientific, medical, and industrial devices, including microwaves, wireless security (camera) systems and W-LAN use the same frequency band as this data collector. Other radio stations also use this frequency for mobile object identification, including local private radio stations that require a license (for example, manufacturing lines at factories), specific power-saving radio stations requiring no license, and amateur radio stations.

Interference from other devices may affect the communication speed or communication range of this data collector or vice versa.

## **9.3. Infrared Transmission (IrDA)**

### **9.3.1. Specifications**

The dedicated cradle enables the OPL 9712 to perform infrared transmission of data with IrDA Ver1.2 low power specification.

### **9.3.2. Transmission Speed**

Default transmission speed is set at 115.2 kbps. However, you can easily change the transmission rate to 57.6 kbps, 38.4 kbps, 19.2 kbps, 9600 bps, 4800 bps, or 2400 bps.

## 10. Default Settings

### 10.1. Default Settings 1: Readable Codes

Symbology	Read	Transmit Code Length	Transmit CD	Calculate CD	Set Prefix	Set Suffix	Other
UPC-A	■	X	■	■	—	CR	
UPC-A Add-on	X	X	■	■	—	CR	
UPC-E	■	X	■	■	—	CR	
UPC-E Add-on	X	X	■	■	—	CR	
EAN-13	■	X	■	■	—	CR	
EAN-13 Add-on	X	X	■	■	—	CR	
EAN-8	■	X	■	■	—	CR	
EAN-8 Add-on	X	X	■	■	—	CR	
Chinese Post	X	X	■	X	—	CR	
Codabar / NW-7	■	X	■	X	—	CR	Not transmit ST/SP
Code 11	X	X	X	■	—	CR	
Code 39	■	X	■	X	—	CR	Not transmit ST/SP
Code 93	■	X	X	■	—	CR	
Code 128	■	X	X	■	—	CR	
GS1-128 (EAN/UCC-128)	X	X	X	■	—	CR	
GS1 DataBar (RSS)	X	X	■	■	—	CR	
IATA	■	X	■	X	—	CR	
Industrial2of5	■	X	■	X	—	CR	
Interleaved2of5	■	X	■	X	—	CR	
Korean Postal Code	X	X	X	■	—	CR	
Matrix2of5	X	X	■	X	—	CR	
MicroPDF417	X	X	—	—	—	CR	
PDF417	X	X	—	—	—	CR	
MSI/Plessey	■	X	■CD1	■CD1	—	CR	
S-Code	■	X	■	X	—	CR	
Telepen	■	X	X	■	—	CR	
Tri-Optic	■	X	—	—	—	CR	Not transmit ST/SP
UK/Plessey	■	X	■	■	—	CR	

**Notes:**

- In the “Reading” column, “■” means “Enable reading” and “X” means “Disable reading.”
- In the “Transmit code length” column, “■” means “Transmit code length” and “X” means “Do not transmit code length.”
- In the “Transmit CD” column, “■” means “Transmit check digit” and “X” means “Do not transmit check digit.”
- In the “Calculate CD” column, “■” means “Calculate check digit” and “X” means “Do not calculate check digit.”
- “—” means “not supported.” In the “Prefix” column, “—” means “there is no prefix setting.”

**11. Serial Number and Labeling****11.1. Serial Number**

The serial number on the right is written on silver matte with black paper affixed to the back of the OPL 9712.

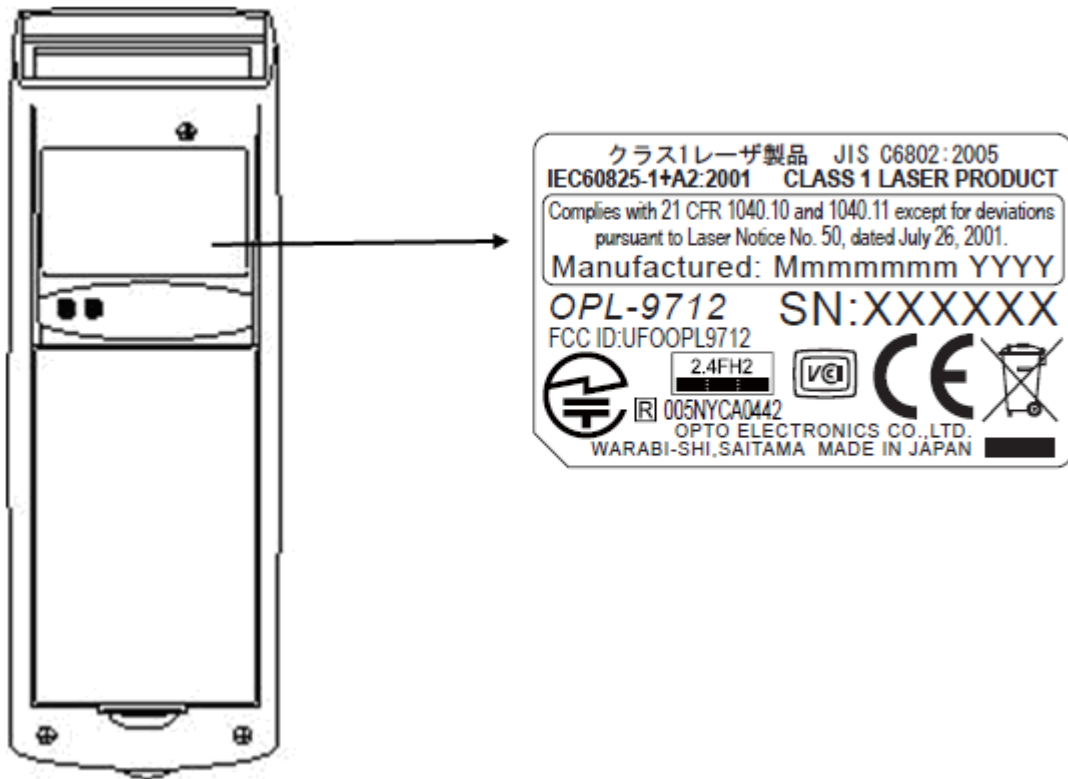

Figure 7: Serial number diagram

Uppercase: Management Barcode

(Symbology: Code 39, Resolution: 0.12 to 0.2, N/W Ratio: 1:2.5 to 1:3)

Lowercase: Model Names, Serial Numbers (The height of letters is  $1.2 \pm 0.3$  )

Serial numbers are seven-digit numbers and start from number 0000001 regardless of batch.

**11.2. FCC Label**

This device complies with part 15 of the FCC Rules. Operation is subject to the following two conditions: (1) This device may not cause harmful interference, and (2) this device must accept any interference received, including interference that may cause undesired operation.

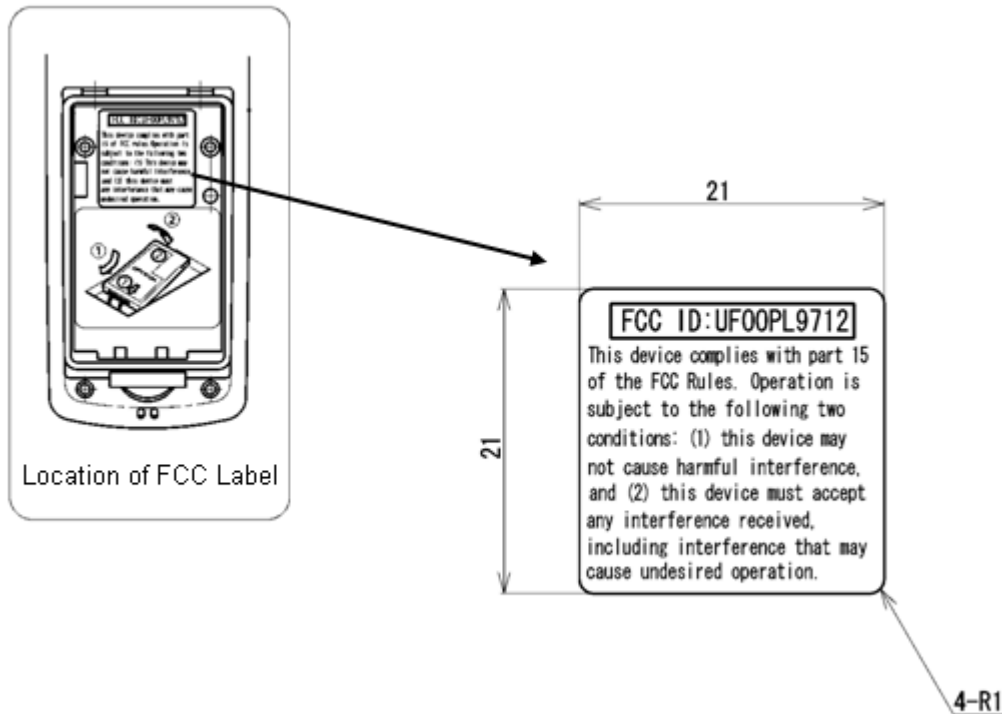

Figure 8: FCC label

## 12. Packaging Specifications

### 12.1. Individual Packaging Specification

Put the data collector in a protective foam bag and place it in an individual packing box, then place the accessories into the box. Close the box and affix a label to the side of the box.

Size of the package after assembly: 245 (W) x 112 (D) x 39 (H) mm

Packaging Instructions

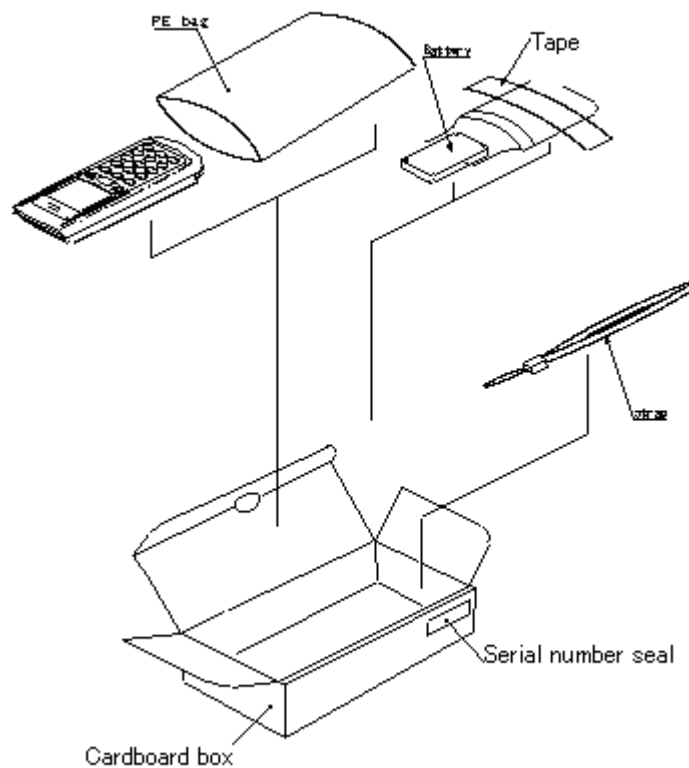

Figure 9: Individual packaging

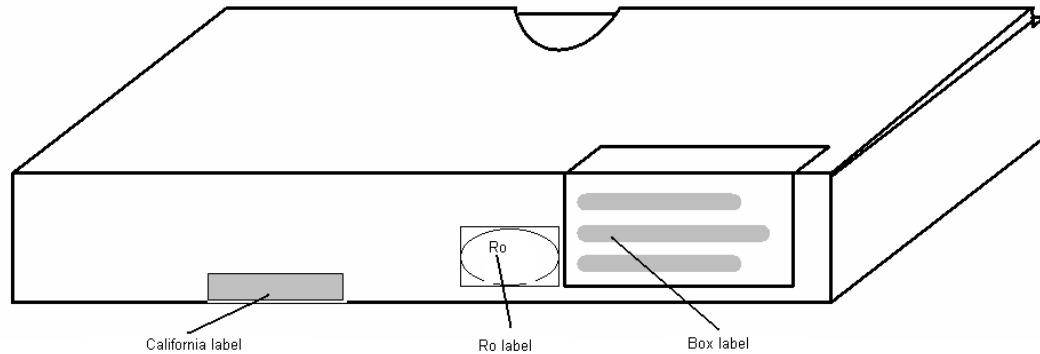

Figure 10: Labels on individual packaging

## 12.2. Accessory Specification

These accessories are enclosed in an individual package:

- 1 lithium-ion battery
- 1 hand strap

## 12.3. Collective Packaging Specification

When packing 50 pre-packaged data collectors, select a box size equal to 560 mm (W) by 490 mm (D) by 195 mm (H).

**Note:** The “RO” mark labeled on the package tray or package box guarantees that the applicable product has passed our test of RoHS restrictions compliance (the restriction of the use of certain hazardous substances in electrical and electronic equipment, 2002/95 EC). However, this document does **not** have any legal weight in the European Union.

## 13. Durability

### 13.1. Shock

#### 13.1.1. Drop Test (without packaging)

No malfunction occurred after the following drop test.

Drop Test: Drop the data collector from a height of 1.5 m onto a concrete floor. Each side of the data collector impacted the floor three times.

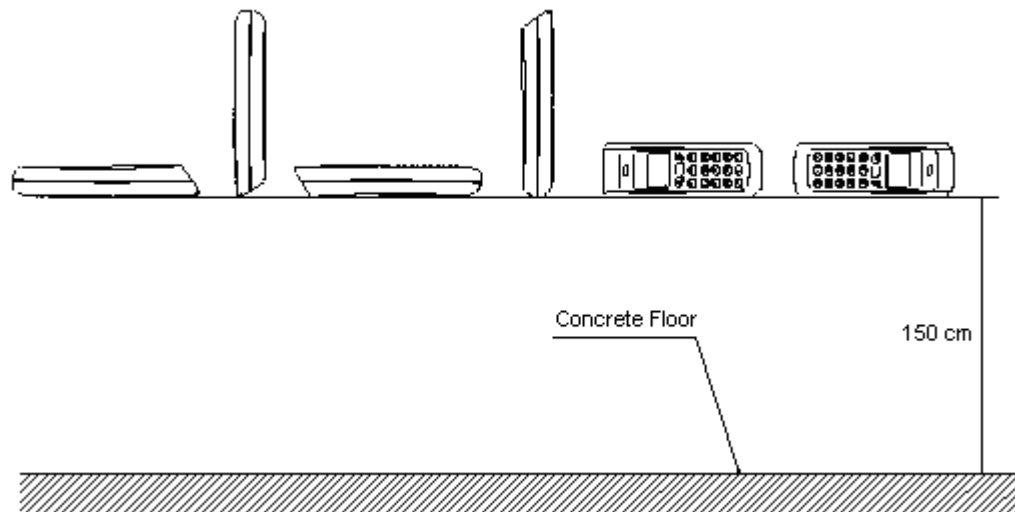

Figure 11: Shock test

### 13.2. Vibration Strength

No malfunction occurred after the following vibration test.

Vibration test: Increase the frequency of the vibration from 12 Hz to 100 Hz with accelerated velocity  $19.6 \text{ m/s}^2$  (2 G) for 6 minutes in non-operating state. Repeat this routine 10 times in each X, Y, Z direction once for a total of 180 minutes.

### 13.3. Dust and Drip Proof

IEC IP54

#### Dust Prevention

Level	Details
5	Ingress of dust is not entirely prevented, but it must not enter in sufficient quantity to interfere with the satisfactory operation of the equipment; complete protection against contact.

#### Water Prevention

Level	Details
4	Water splashing against the enclosure from any direction shall have no harmful effect.

## 14. Reliability

MTBF (Mean Time Between Failures) of this product except for the laser diode and the mirror motor scan unit is 8 years.

Life cycle of the laser scan engine (including the life cycle of the laser diode and the mirror motor) is 10,000 hours.

Keypad operating life: The keypad expected usability is 1,000,000 uses (cycles) when the key is pressed with 1 kgf force.

The estimate of MTBF and product life cycle is based on standard operation of the product within the recommended temperature range and without extreme electronic or mechanical shock.

The MTTR (Mean Time To Repair) of this product is one hour.



## 15. Regulatory Compliance

### 15.1. Laser Safety

The data collector emits laser beams.

JIS C6802: 2005: Laser class 1

IEC 825-1/EN 60825-1: Laser class 1

FDA CDRH Laser class I. Complies with 21 CFR 1040.10 and 1040.11 except for deviations pursuant to laser notice No. 50 dated June 24, 2007.

Class I laser devices are not considered to be hazardous when used for their intended purpose. Avoid staring into the laser beam.

### 15.2. Product Safety

EN60950-1: 2001

IEC60950-1: 2001

### 15.3. EMC

EN55022

EN55024

VCCI Class B: This is a Class B product, to be used in a domestic environment based on the Technical Requirement of the Voluntary Control Council for Interference from Information Technology Equipment (VCCI). If this is used near a radio or television receiver in a domestic environment, it may cause radio interference. Please install and use the equipment according to the instruction manual.

FCC Part 15 Subpart B Class B: This device complies with part 15 of the FCC Rules. Operation is subject to the following two conditions: (1) this device may not cause harmful interference, and (2) this device must accept any interference received, including interference that may cause undesired operation.

FCC ID: UFOOPL9712

### 15.4. RoHS

RoHS: The restriction of the use of certain hazardous substances in electrical and electronic equipment, 2002/95 EC.

### 15.5. R&TTE

This data collector conforms to the following standards of the Radio and Telecommunications Terminal Equipment (R&TTE) directive from the EU.

EN300 328

EN301 489-1

IEC60950-1

EN60950-1

**15.6. Radio Law**

The data collector qualifies as radio equipment for low-power radio stations (2.4 GHz band advanced data communication systems) as specified in the Radio Law 38-24-1.

The data collector has obtained the Certification for Construction Design of Specified Radio Equipment. It does not have a radio station license in Japan.

The following activities are prohibited under the Radio Law:

Remodeling and disassembly

Peeling off the certificate label

**15.7. State of California: Perchlorate Best Management Practices**

The batteries on some Opticon products may contain Perchlorate. To comply with California Perchlorate Best Practice Regulations and the Law for the Promotion of Utilization of Recyclable Resources (Japan), products that may contain Perchlorate materials should be properly labeled on the exterior of all outer shipping packages and/or in locations that otherwise satisfy the California Perchlorate Best Management Practices.

## 16. Safety

Handle this product carefully. Do not deliberately subject it to any of the following.

### 16.1. Shock

Do not throw or drop the data collector.

Do not drop or put heavy items on this product or its cable.

### 16.2. Temperature Conditions

Do not use the data collector at temperatures outside the specified range.

Do not use near heat sources such as radiators, heat registers, stoves, or other types of devices that produce heat.

Do not use in areas exposed to direct sunlight for long periods of time.

Do not pinch or forcibly bend the cable, especially at very low temperature.

### 16.3. Foreign Materials

Do not use the data collector near water or other liquids, as well as in extremely high humidity.

Do not immerse the data collector in liquids.

Do not use in dusty environments.

Do not subject the data collector to chemicals.

Do not insert foreign substances into the device.

### 16.4. Other

Do not plug/unplug the connectors before disconnecting the power.

Do not attempt to disassemble, modify or update this device.

Do not use near microwaves, medical devices, or RF-emitting devices.

The data collector may not perform properly in environments when placed near a flickering light, such as a computer monitor, television, etc. Do not use in the reach of blinking lights such as CRT.

The data collector may be damaged by voltage drops.

**17. Mechanical Drawing**

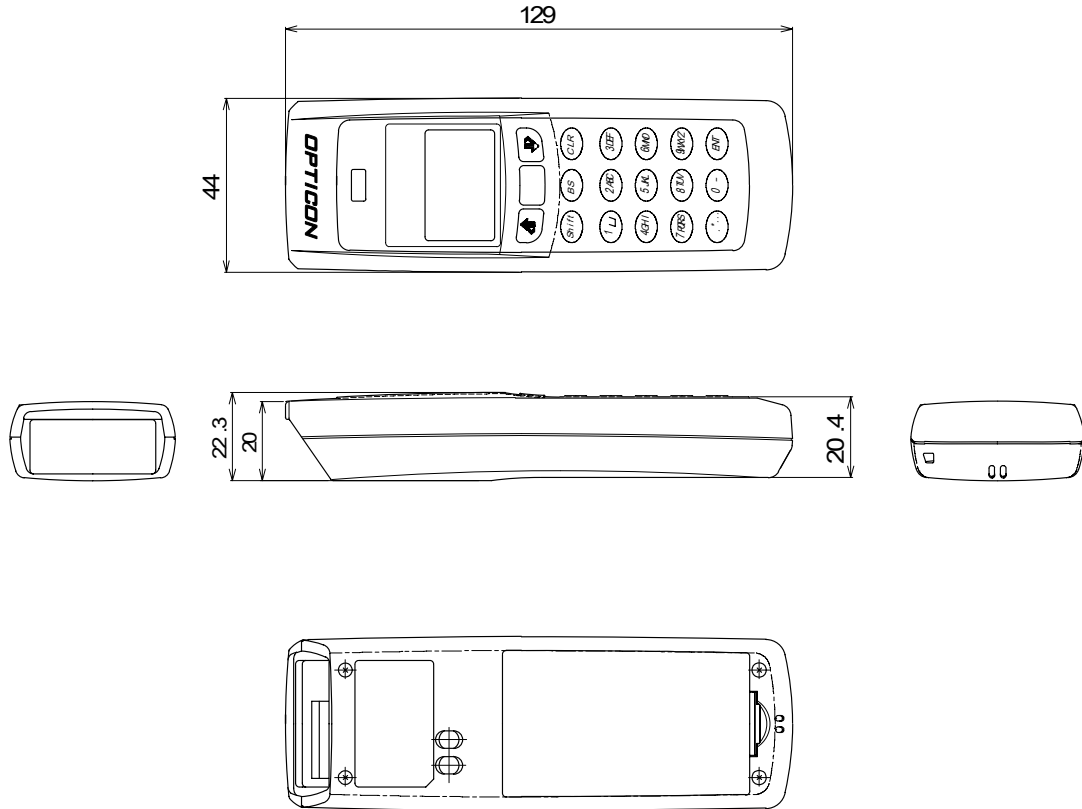

*Figure 12: Mechanical drawing*